

Trophic Model of the Coastal Fisheries Ecosystem of the West Coast of Peninsular Malaysia

Alias Man

Fisheries Research Institute (FRI)
11960 Batu Maung, Penang, Malaysia

Alias, M. 2003. Trophic Model of the Coastal Fisheries Ecosystem of the West Coast of Peninsular Malaysia, p. 313 - 332. *In* G. Silvestre, L. Garces, I. Stobutzki, M. Ahmed, R.A. Valmonte-Santos, C. Luna, L. Lachica-Aliño, P. Munro, V. Christensen and D. Pauly (eds.) *Assessment, Management and Future Directions for Coastal Fisheries in Asian Countries*. WorldFish Center Conference Proceedings 67, 1 120 p.

Abstract

A preliminary mass-balance trophic model was constructed for the coastal fisheries ecosystem of the West Coast of Peninsular Malaysia (0 - 120 m depth). The ecosystem was partitioned into 15 trophic groups, and biomasses for selected groups were obtained from research (trawl) surveys conducted in the area in 1987 and 1991. Trophic interactions of the groups are presented. The network analysis indicates that fishing fleets for demersal fishes and prawns have a major direct or indirect impact on most high-trophic level groups in the ecosystem.

Introduction

The fisheries ecosystem of the West Coast of Peninsular Malaysia, (WCPM); between 98° to 104° E longitude, and 1° to 7° N latitude) from the coastline to the EEZ border (20 - 120 m depth) was studied (Fig. 1). Fish landings from the area contributed about 50% of total landings in the country. The total marine area is about 20 400 nm², including about 263 nm² of islands in the north. The Langkawi group of islands is the largest with a total land area of about 140 nm². Apart from mangroves, some of these islands adjoin unique coral reefs. Pulau Payar, an island gazetted as a marine park, is one of the most diverse coral reef ecosystem in Malaysia. The sheltered waters of the west coast, which have muddy substrate are trawled year round.

Based on analyses of demersal community structure (Alias, this vol.), the waters of the WCPM can be divided into two main assemblages (coastal, < 40-m; offshore, > 40-m). The mangrove-related communities are found all along the coast, in waters of up to 40 m depth. The commercially most important species group in this community comprise of prawns. Small-sized fishes including slip-

mouth (Leiognathidae) are also predominant in the coastal areas.

Off the WCPM, the waters within the EEZ rarely exceed 120 m, the deepest part being at the northern tip of the Straits of Malacca. In general, WCPM is shallow, with a huge mud flat area (< 10 m) running northwest from the central part of the coast (Fig. 1).

In the Straits of Malacca, currents generally flow in a northwestern direction throughout the year. Tidal action is not appreciable beyond a distance of about 8 miles off the northern coast of Sumatra and about 40 miles off the northeast coast. During the northeast monsoon period (October-April), its current flow is a branch of the southward monsoon current in the South China Sea, which rounds the extremity of the Malay peninsula and passes into the strait. During the southwest monsoon period (May-September), part of the water which flows westward in the Java Sea and northward through the Karimata Strait towards the South China Sea also passes directly into the Malacca Strait (Hydrographic Department. Admiralty 1964).

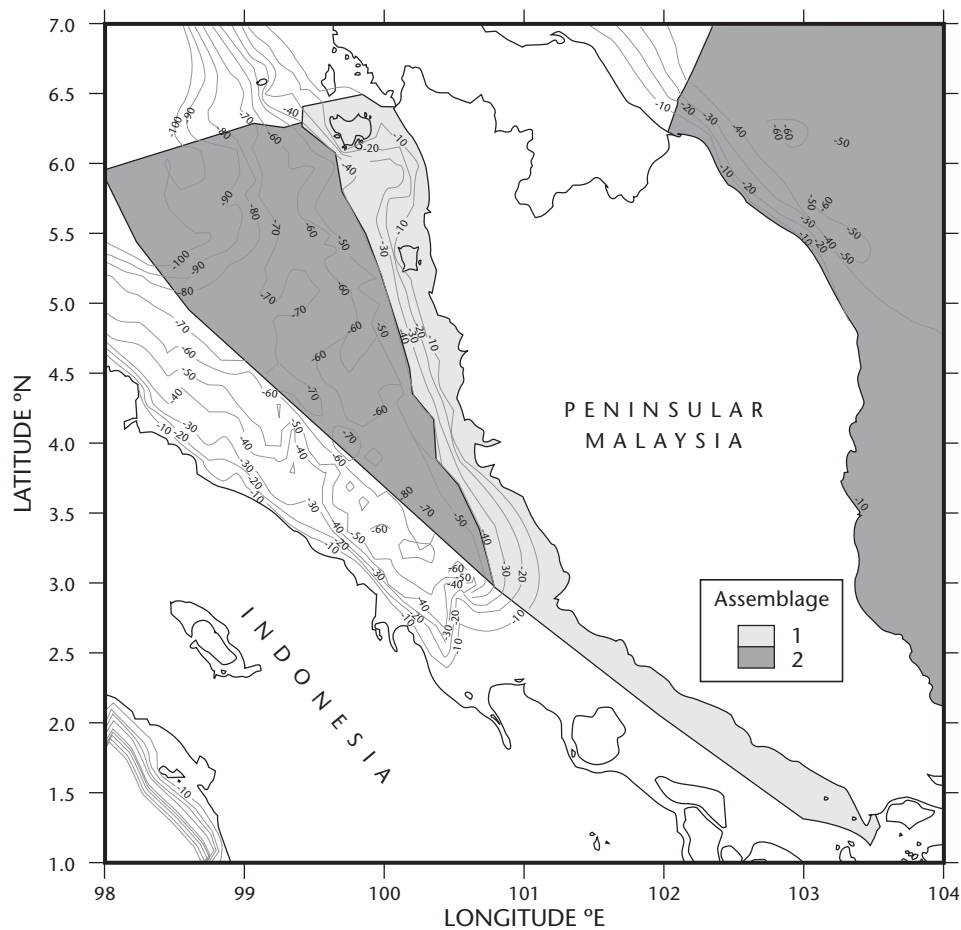

Fig. 1. Map of the West Coast of Peninsular Malaysia WCPM showing delineation of fishing area by fish assemblage. Isobaths are in meters.

Currents exceeding the rate of one knot may be experienced throughout the year in the strait. When the currents are most constant (December - February), only about 17% of all observed rates exceed one knot in northwesterly directions.

Studies of primary productivity were conducted only off the East Coast of Peninsular Malaysia and in waters off Sarawak. Average surface concentration of chlorophyll *a* in waters off the East Coast of Peninsular Malaysia is $0.08 \text{ mg}\cdot\text{m}^{-3}$, and the average value is $0.208 \text{ mg}\cdot\text{m}^{-3}$ (Raihan and Ichikawa 1986). Similarly low concentrations of chlorophyll *a* are observed in Sarawak waters, ranging between 0.049 to $0.150 \text{ mg}\cdot\text{m}^{-3}$ throughout the water column (Lokman et al. 1988). On the East Coast, the density of particulate organic carbon from the sea

surfaced to 50 m depth ranged from 3.9 to $6.0 \text{ gC}\cdot\text{m}^{-2}$ (Ichikawa 1986), and from 3.7 to $6.0 \text{ gC}\cdot\text{m}^{-2}$ in Sarawak waters (Ichikawa and Law 1988).

The WCPM ecosystem comprises four main habitats: mangrove mud flats, seagrass beds, coral reefs, and muddy-sandy bottoms. The mangrove areas are in the state of Perak (40 000 ha), Johor (25 600 ha), Selangor (22 500 ha) and Kedah (9 000 ha) (Choo et al. 1994). The Larut Matang mangroves in Perak were reported to be the largest mangrove forest in Peninsular Malaysia and possibly the best managed mangrove forest in the world (Gong et al. 1980). There have been numerous studies showing the linkage of mangroves to fishery resources (Malaysian Coastal Resources Study Team (MCRST), 1992).

The coral reef areas of the WCPM are found around islands located to the north of Kedah (Payar Islands) and off Perak (Sembilan Islands). There are also small isolated fringing reefs occurring along the mainland coast. There are at least five large seagrass beds off the WCPM (Kushairi 1992). Five species of seagrass are found in shallow waters between 0.2 and 1.8 m, namely: *Halophila ovalis*, *H. uninervis*, *H. pinifolia*, *H. minor* and *Enhalus acoroides*.

Beyond 40 m, the seabed is generally muddy with small spots of sandy bottom. These constitute a different habitat altogether with a different faunal assemblage, also targeted by trawl fishery.

The fishery of the WCPM is multispecies and multigear. There are about twelve main fishing gears used, catching a multitude of fish and invertebrate species. Trawls are the main type of fishing gear, accounting for about 60% of total WCPM landings.

The fishery resources on the WCPM are being over-harvested. Statistics show that landings in 1996 were 460 302 t, but abundance trends from resource surveys indicate that the resources have declined to only 25% of the original levels (Talib et al. this vol.). Steps have been taken to sustain the WCPM fishery and access is now closed to new entrants to the sector. The focus is now to exploit resources in the EEZ waters off Sarawak.

Previous work on multispecies fisheries and marine ecosystems in Malaysia include a study of the East Coast of Peninsular Malaysia, based on an early version of the Ecopath model (Liew and Chan 1987), while (Alias, 1994) presented multispecies surplus production models for the WCPM based on analysis of catch and effort data on 30 different groups of species. However, analyses at the ecosystem level have so far not been conducted in the WCPM.

Materials and Methods

The Ecopath Model

The master equations of the Ecopath model of (Polovina, 1984) as modified by (Christensen and Pauly, 1992), assumed that the system is in mass-balance, where input for a given group i equals output, i.e.

$$\text{Consumption (i)} = \text{production (i)} + \text{unassimilated food (i)} + \text{respiration (i)} \quad (1)$$

In addition, the production of group i in the system can in its simplest form be expressed as:

$$\text{Production (i)} = \text{predation mortality (i)} + \text{catches (i)} + \text{other mortality (i)} \quad (2)$$

where the predation mortality terms are used to link the predator and prey species. Equation (2) can also be expressed as:

$$P_i - M2_i - P_i (1 - EE_i) - EX_i = 0 \quad (3)$$

where P_i is the production of (i), $M2_i$ is the total predation mortality of (i), EE_i is the ecotrophic efficiency of (i) or the proportion of the production that is either exported or predated upon, $(1 - EE_i)$ is the "other mortality", and EX_i is the export or catch of (i).

Equation (3) can be re-expressed as:

$$B_i * PB_i - \sum_{j=1}^n B_j * QB_j * DC_{ji} - PB_i * B_i (1 - EE_i) - EX_i = 0 \quad (4)$$

where B_i is the biomass of (i), PB_i is the production/biomass ratio, QB_j is the consumption/biomass ratio and DC_{ji} is the fraction of prey (i) in the average diet of predator (j).

From the first four parameters B_i , PB_i , EE_i and QB_j , one may be unknown, to be estimated when the balancing routine is run. The DC_{ji} and EX_i are always required for all groups.

Later versions of the Ecopath model are more dynamic, with the non-predation losses (Eq. 2) broken up into migration, biomass accumulation and other mortality. Equation (2) becomes:

$$\text{Production} = \text{fishing mortality} + \text{predation mortality} + \text{migration} + \text{biomass accumulation} + \text{other mortality} \quad (5)$$

Ecological Groups

Table 1 presents the ecological groups used for the construction of the Ecopath model of the WCPM. Appendices A & B show the list of species from (FAO 1997) as well as the species in the WCPM.

To model the ecosystem, all species therein need to be grouped according to their trophic characters. Then, the biomass and the catch of each trophic group need to be provided. Trophic grouping used by (Pauly and Christensen 1993) for modeling the

South China Sea was used, with some modification to fit the WCPM ecosystem, such as the diadromous fishes, mammals and turtles. The mammals and turtles were included in the system although information on these groups is incomplete.

Table 1. Ecological groups used in the Ecopath modeling of the waters off the West coast of Peninsular Malaysia.

Ecological group	Taxa
Benthic producers	Brown, red and green seaweeds Other algae Misc. aquatic plants
Crustacean (excl. plankton)	Crabs Spiny and Slipper lobster Banana prawn, Giant tiger prawn, Greasy-back prawn/Pink prawn, Rainbow prawn, Red prawn, Sand prawn, Sharp-rostrum prawn, Small white prawn, Yellow shrimp Misc. marine crustaceans
Intermediate predators	Barramundi (Giant seaperch), Bombay-duck, Catfish eel, Croakers/Jewfish, Emperors/Scavengers, False trevally, Fusilier, Goatfish, Grouper, Grunter, Lizard fish, Mangrove snapper, Marine catfish, Mojarras/Silver biddies, Monocle bream, Parrotfish, Pony fishes/Slipmouth, Rabbitfish/Spinefeet, Red snapper, Russell's snapper, Sharp-toothed bass, Sillago whittings, Snapper, Spadefish, Spotted sicklefish, Sweetlips, Threadfin bream, Triggerfish, Misc. demersal commercial fishes Black kingfish/Cobia, Leatherskin/Queenfish, Rainbow runner, Threadfin, Dorab wolf-herring Mixed fish (mainly demersal)
Large pelagics	Frigate tuna, Kawakawa, Longtail tuna, Sailfish/Marlin Spanish mackerel/King mackerel
Large predators	Conger eel Barracuda Shark
Large zoobenthos feeders	Ray
Mammals	Dolphins, Porpoises, Dugong
Medium pelagics	Amberjack, Black pomfret, Chinese silver pomfret, Golden trevally, Horse mackerel/Trevally, Silver pomfret, Small pomfret, Misc. pelagic commercial fishes Largehead hairtail
Misc. invertebrates	Abalones, winkles, conchs, etc. Rock oyster/Flat oyster Brown mussel Scallops, pectens, etc. Blood cockle, Other clams, Undulate venus Misc. marine mollusks Sea-squirts and other tunicates Horseshoe crabs and other arachnoids Sea cucumbers Jellyfish Pearls, mother-of-pearl, shells, etc. Corals Sponges

Table 1. Ecological groups used in the Ecopath modeling of the waters off the West coast of Peninsular Malaysia. (continued)

Ecological group	Taxa
Small demersal prey species	Chacunda gizzard shad, Longtail shad, Shad, Slender shad Elongate ilisha Flatfish, Tonguefish/ tongue sole Misc. demersal trash fishes Trash fish (mainly demersal)
Small pelagics	Bigeye scad, Hardtail scad/Torpedo scad, Mullet, Round scad, Selar scad, Yellowstripe scad Anchovy, Fringescale sardinella, Indo-Pacific tarpon, Rainbow sardine Indian mackerel/Short mackerel Misc. pelagic trash fishes
Squids and cuttlefishes	Common squid, Cuttlefish, Octopus
Turtles	Green turtles
Zooplankton	Sergestid shrimp

Table 2. Basic input parameter values used in modeling the coastal fisheries ecosystem off the West coast of Peninsular Malaysia.

Ecological group	Biomass (t·km ⁻²)	P/B (year ⁻¹)	Q/B (year ⁻¹)	EE	Catch (t·km ⁻² ·year ⁻¹)
Mammals	0.02	0.05	30.00	–	–
Large predators	0.02	2.86	7.30	–	0.03
Large pelagics	–	3.93	9.55	0.95	0.67
Medium pelagics	–	2.43	10.00	0.95	0.13
Large zoobenthos feeders	–	3.90	7.85	0.95	0.07
Intermediate predators	0.03	7.49	15.00	–	3.23
Small demersal species	–	10.00	23.74	0.95	0.14
Small pelagics	–	3.75	12.9	0.95	0.13
Crustaceans (excl. plankton)	–	5.11	21.81	0.95	0.82
Misc. invertebrates	–	5.51	11.02	0.95	0.06
Squids	–	4.10	10.51	0.95	0.29
Turtles	0.02	1.50	3.50		–
Zooplankton	–	67.00	280.00	0.95	0.19
Aquatic plants	–	71.15	–	0.50	–
Detritus	100.00	–	–	–	–

Note: P/B = Production/Biomass ratio, Q/B = Consumption/Biomass ratio, EE = Ecotrophic efficiency.

Model Parameterization

To describe the west coast fisheries ecosystem, parameters are required for the Ecopath software. Table 2 gives a summary of the basic input parameters used in the construction of the Ecopath model for the study area.

Biomass Estimates

Most biomasses were estimated from the catch rate of demersal trawl surveys using the swept area-method (see Appendix A). Two different types of demersal survey were conducted in the area, i.e. the coastal and offshore surveys, both conducted in different areas and years. To determine the biomass for the total area, information from the offshore and coastal survey was combined. The closest gap in time pertains to the 1987 offshore survey and the 1991 coastal survey. In this study, the ecosystem was modeled based on the 1991 scenario. The composition of the offshore demersal assemblage in 1987 was assumed to be similar to 1991. However, the 1987 demersal biomass values were reduced by 26% before they were combined with the 1991 biomass of the coastal demersal stocks due to differences in the survey period. The reduction was based on the trend of decline for the period 1987 - 91 (see Talib et al. this vol.).

Estimated biomass should be corrected for varying catchability coefficient; a value of 0.5 is commonly used for trawl surveys in South East Asian waters (Pauly 1984) and this was used here for the estimation of demersal fish biomass in deeper waters. For pelagic species, this value should be much lower due to the gear being inefficient in catching pelagics. In this study, it is assumed that the catchability of pelagic species is half of those for demersal species, i.e. 0.25. The deeper assemblage can be sampled best using a fish trawl as the sampling gear. However, a prawn trawl best samples the shallower assemblage. As the coastal demersal fish survey can only cover the area from 5 m depth and above, the biomass in less than 5 m depth could not be determined. In this study, the initial biomasses for the shallow areas were corrected by assuming catchability equal to that of pelagics.

The Ecopath model was used to estimate the biomass of other groups, such as marine mammals and reptiles. As some of the biomasses estimated via the swept-area method were likely to be underestimates, it was decided to estimate these based on

ecosystem demand (i.e. as outputs of Ecopath) and compare these estimates to those from the swept-area method.

Production to Biomass Ratios (P/B)

P/B ratio estimates were mostly obtained from total mortality estimates (Z) derived using length-based methods (Chee and others, 1998). For the crustacean, large pelagics and zooplankton groups, the P/B values were adopted from Silvestre et al. (1993) (see Appendix A). Assuming that biomass for these groups were underestimated, the biomass values were adjusted such that fishing mortality (F) is equivalent to Z minus natural mortality (M).

Consumption to Biomass Ratio (Q/B)

For initial parameterization, Q/B values were estimated from the average of values obtained from the literature (Appendix B), except for the zooplankton group, where the value from Silvestre et al. (1993) was used. The Q/B for mammals was assumed to be similar to that of large predatory fishes.

Diet Composition

The diet composition (Table 3) was estimated based on the work of Liew and Chan (1987) and Silvestre et al. (1993). The diet composition for mammals and turtles was based on the researchers' general knowledge about the groups and their eating habits.

Catches

Landings were obtained from statistics (DOF 1992), even though the exact location of capture could not be established (Appendix C). However, information on distance from shore is implicit in the type of fishing gear used. Legally, all gears are allocated a fishing area. The main task was to reclassify the landings by various fishing gears to landings by fishing area, so that landings as well as biomass from any fishing area could be calculated. This reclassification process involved three steps, i.e. classification of fishing area, classification of fishing gears, and classification of resources/species:

Area Classification. The fishing area has been legally classified into four zones based on distance from shoreline. Zone A is from the shoreline to 5 nm, Zone B is from 5 to 12 nm, Zone C is from 12 to 30 nm, and Zone D is from 30 nm onward.

Zone A is allocated solely for traditional small-scale fishing gears. The zoning system was established after introduction of commercial fishery and was intended to reduce conflict between traditional and commercial fishers. The zoning system does not seem to be based on any scientific study and criteria used for the boundary delineation are unclear. Alias (this vol.) reported two main species assemblages off the West Coast of Peninsular Malaysia. The first assemblage occurs over the shallow area (0 - 40m) roughly matching Zones A and B, and the second assemblage occurs over a deeper area (> 40m) roughly matching Zones C and D.

Fishing Gear Classification. From cluster analysis of the catches of various fishing gears in species space, the fishing gears can be classified into five main groups (Table 4). Information on their areas of operation and species assemblages fished is also given in Table 4.

Species Classification. A ‘miscellaneous fishes’ category is commonly used in landing statistics and research (trawl) surveys. It includes both demersal and pelagic fishes. From an ecological perspective, these fishes are very different in terms of feeding behavior and diet composition, although they are usually all assigned to the ISSCAAP (Group 39). Difficulties arise during the trophic grouping of species, but especially so for this group. Here the task was to reclassify this group properly. For the trawl survey data, the “miscellaneous fishes” were broken down to species level and then assigned to the appropriate group. For the landings data, the miscellaneous group and “trash fish” were assigned to groups according to the type of gear that caught them. For example, “trash fish” landings of the trawl were assigned to the demersal fishes group because most of the catch was demersals. For the purse seine, the “trash fish” was assigned to the pelagic group as most of the catch is pelagics.

Table 3. Diet composition of the 15 ecological groups used in the analysis - the predator numbers correspond to the prey numbers.

Prey	Predator												
	1	2	3	4	5	6	7	8	9	10	11	12	13
1. Mammals													
2. Large predators	0.03												
3. Large pelagics	0.66												
4. Medium pelagics		0.10	0.10	0.04									
5. Large zoobenthos feeders		0.01	0.01										
6. Intermediate predators	0.01	0.34	0.34	0.82		0.01		0.05					
7. Small demersal species		0.01	0.01	0.00		0.01							
8. Small pelagics	0.30	0.50	0.50	0.04		0.01		0.01					
9. Crust. (excl. plankton)				0.09	0.68	0.54	0.06	0.05	0.09	0.05	0.08	0.10	
10. Misc. invertebrates					0.17	0.26	0.06		0.13	0.05	0.06	0.10	
11. Squids		0.05	0.05	0.01	0.15	0.15			0.10		0.02		
12. Turtles													
13. Zooplankton						0.01	0.88	0.70	0.08	0.30	0.10		0.10
14. Aquatic plants								0.19	0.03	0.10	0.10	0.80	0.65
15. Detritus						0.01			0.58	0.50	0.64		0.25
Sum	1.00	1.00	1.00	1.00	1.00	1.00	1.00	1.00	1.00	1.00	1.00	1.00	1.00

Table 4. Classification of fishing gears into five main groups. The zone of operation refers to the management zones and the assemblage refers to Figure 1.

Fishing Gear Group	Main Target Species	Fishing Gear	Zone of Operation	Assemblage	Distance range from shore (miles)	Average depth range (m)
1	Anchovy	Anchovy purse seine	A	1	0 - 5	0 - 20
2	Pelagic fishes	Fish purse seine	B	1	5 - 12	20 - 40
			C	2	12 - 30	40 - 60
			D	2	30 - EEZ	60 - 100
3	Demersal fishes and prawns	Trawlers, drift nets, hooks & lines and portable traps	B	1	5 - 12	20 - 40
			C	2	12 - 30	40 - 60
			D	2	30 - EEZ	60 - 100
4	Prawn	Other seine nets, bag nets, barrier nets, push nets & other traditional nets	A	1	0 - 5	0 - 20
5	Shellfishes	Shellfishes collection	A	1	0 - 5	0 - 20

Fish Prices

The wholesale value of fish was obtained from the annual statistics (DOF 1992). The price of fish was grouped into six main groups. Table 5 below gives a summary of the wholesale value of fish in 1991. All prices are in the Malaysian currency, RM. The exchange rate in 1991 was RM2.50 to US\$1.00.

Results and Discussion

Trends in Commercial and Research Trawl Survey Catches

Fig. 2 shows the trend in stock density of fishes from trawl surveys in coastal and offshore areas from 1971 to 1997 off the WCPM.

In terms of surplus production models, the abundance that generates maximum sustainable yield (MSY) is 50% of the unexploited stock. The present biomass level on the west coast is estimated as 10 - 15% (Talib et al. paper no.6). Fig. 3 shows the trend in catches for the whole area from 1969 to 1996; catches have reached about 500 000 t. This trend suggests that the fisheries have been expanding geographically, an issue not pursued here.

Table 5. Wholesale value (in Malaysian Ringgit, RM) of fish by category in 1991.

Group	Sub-group	Type of Catch	Price (RM·kg ⁻¹)
Fish	Grade 1	Pomfrets, threadfins, spanish mackerels, wolf herrings and grouper	8.27
Fish	Grade 2	Mangrove snappers, longtail shads, shads, red snappers, sweetlips, horse mackerels and giant seaperch	1.33
Fish	Grade 3	Other fish species including anchovies, squids, crabs and jellyfishes.	2.00
Prawn		All types of prawn	5.02
Trash fishes		Trash Fish	0.30
Shellfish		All types of shellfishes	1.08

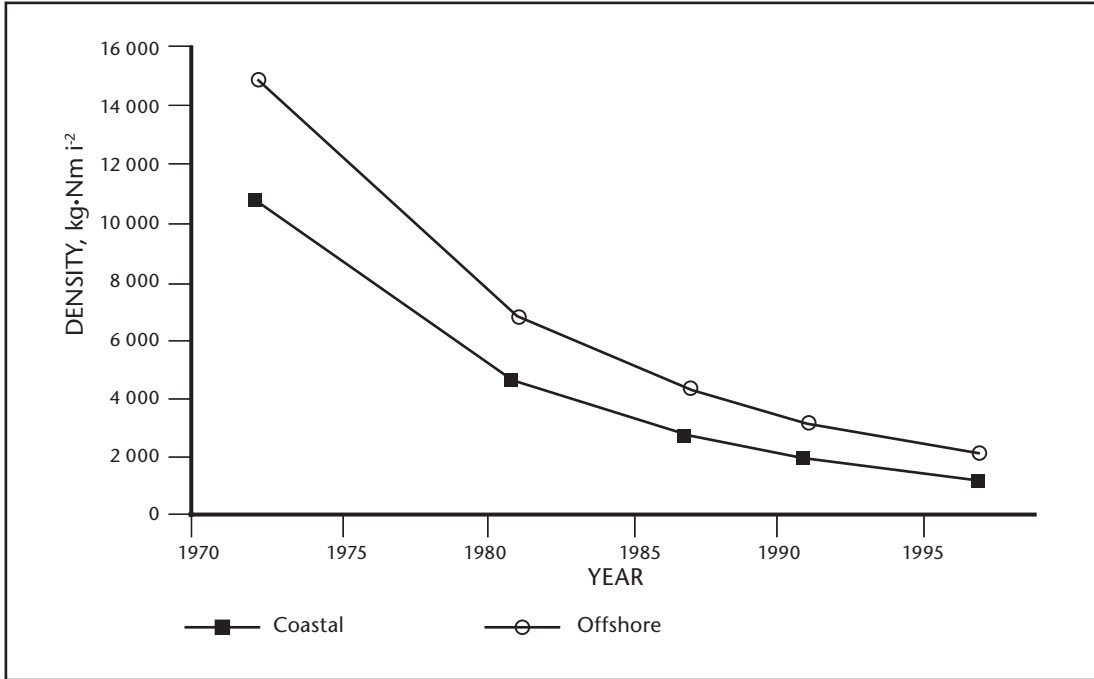

Fig. 2. Total density of fish from research vessel surveys in coastal (1) and off-shore (2) waters off the West Coast Peninsular of Malaysia (WCPM).

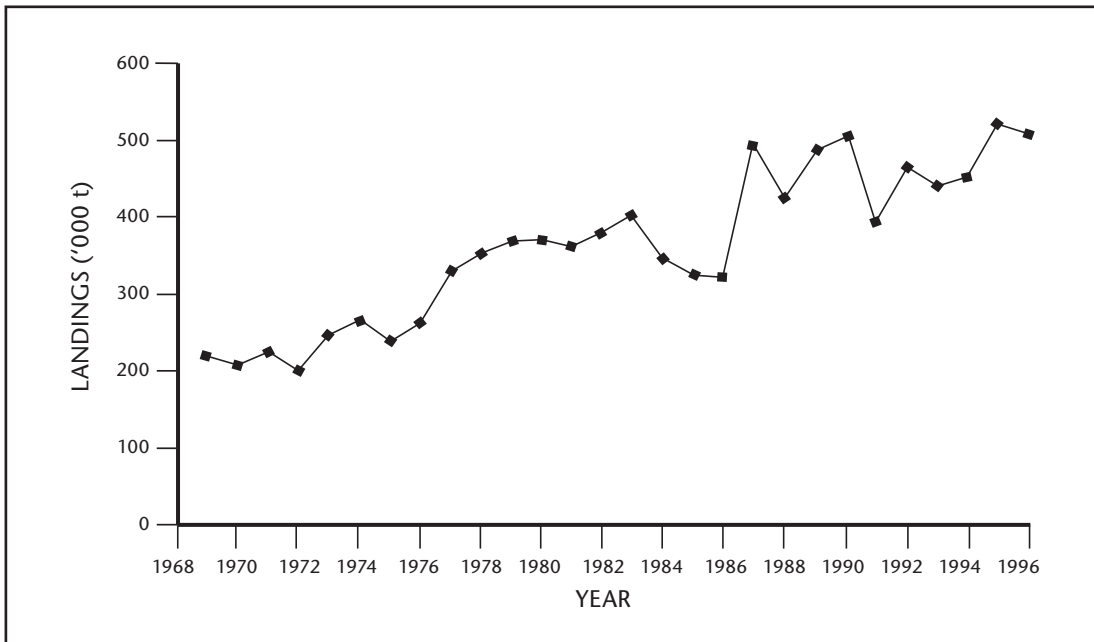

Fig. 3. Total annual landings from the West Coast of Peninsular Malaysia, 1968 - 96.

Trophic Model for the West Coast of Peninsular Malaysia

The model presented below is very preliminary, and will have to be refined before it can be used to provide a basis for the policy exploration that can be performed via Ecopath with Ecosim Software. Ecopath produces a variety of outputs, of interest not just for fisheries management but also for ecological purposes. It is not feasible to reproduce all of these here, but a few may be highlighted. Table 6 presents the biomasses that were input into the model or calculated by Ecopath to ensure mass-balance. Overall, Ecopath requires considerably higher biomass than was estimated by the research trawl surveys especially for the invertebrates and small pelagic groups. Still, some biomasses seem lower than expected (e.g. large predators), which may be due to the overestimation of the P/B ratios.

Figure 4 presents a flowchart of the trophic interactions in the ecosystem. The estimated mean trophic level of the fisheries catch is about 3.2. Fig. 5 documents the impact any of the groups or fishing fleets in the model has on all other groups or fishing fleets through resource competition or direct predation. From this it can be concluded that the fleet fishing for demersals and prawns has a major negative impact on many groups (particularly large zoobenthos feeders and large predators).

This basic Ecopath model can serve as the basis for further analysis of the fisheries and ecosystem, using temporal and spatial dynamic simulation. To give an indication on the sort of analyses that may be carried out through the use of the Ecopath with Ecosim model software (Christensen et al. 2000; Pauly et al. 2000; Walter et al. 1997), a few preliminary runs using Ecosim were conducted.

Table 6. Comparison of biomass (t·km⁻²) estimates as obtained from trawl surveys and the Ecopath model. Values in parenthesis are input assumption. Note that Ecopath estimates are considerably higher for groups with low catchability to the trawl survey gear.

Ecological group	Biomass trawl survey	Biomass Ecopath	Survey/Ecopath Biomass ratio
Large predators	0.02	(0.02)	1.00
Large pelagics	< 0.01	0.14	0.05
Medium pelagics	0.13	0.14	0.92
Large zoobenthos feeders	0.03	(0.03)	1.00
Intermediate predators	0.56	0.71	0.79
Small demersal species	0.01	0.02	0.55
Small pelagics	0.06	0.66	< 0.01
Crust. (excl. plankton)	0.01	3.98	< 0.01
Miscellaneous invertebrates	0.02	3.32	< 0.01
Squids, cuttlefishes	0.14	2.80	0.05

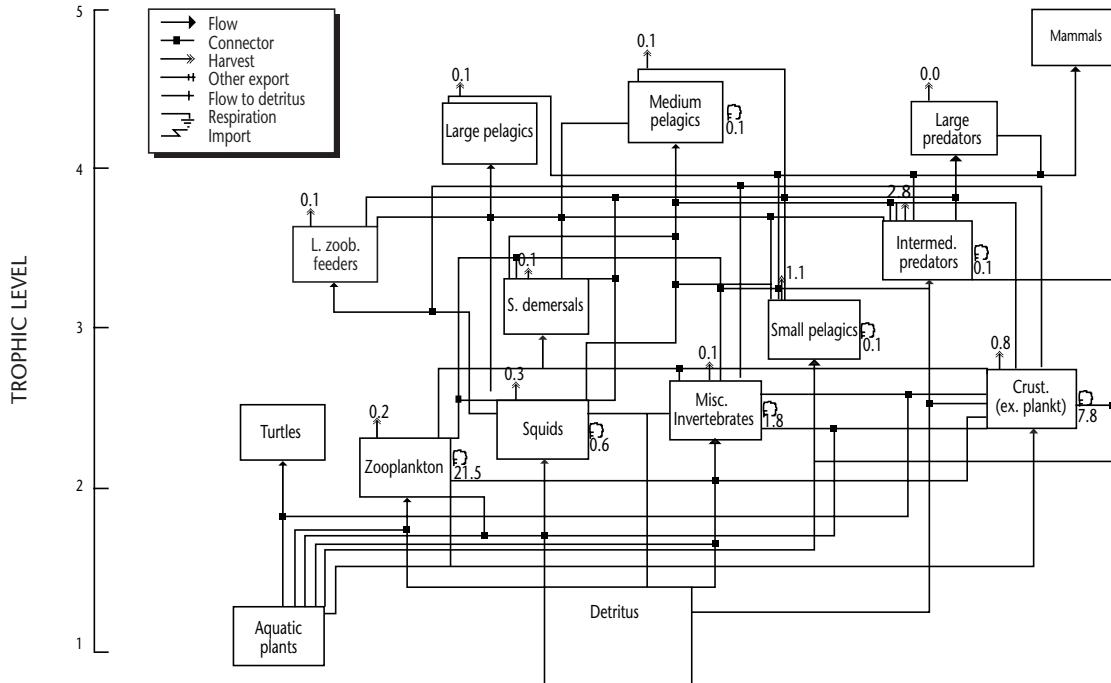

Fig. 4. Flow chart of trophic interactions along the West Coast of Peninsular Malaysia. The model includes 15 groups and five fisheries (not shown), and the groups are arranged on the flow chart by their trophic levels as estimated by Ecopath.

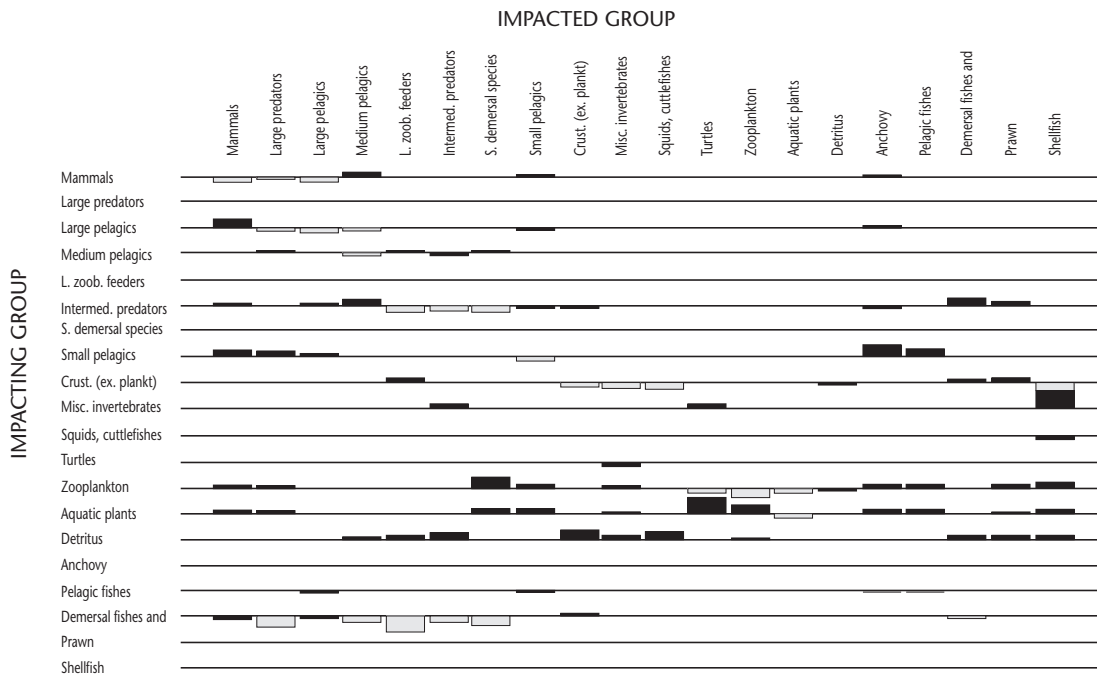

Fig. 5. Mixed trophic impact in the Ecopath model of the West Coast of Peninsular Malaysia. The graph shows the impact the groups to the left (rows) have on the groups mentioned above (columns). Positive impacts are shown above the baseline, and negative below. The impacts are relative but comparable between groups. The last five rows refer to fishing fleets.

The simulations in Table 7 indicate that if overall fishing effort in the WCPM ecosystem was lowered (to 20% of the level in the Ecopath model for 1991) the impact on catches would be limited. Most fleets would catch the same amount. Only the “anchovy” fleet targeting small pelagics would be severely (negatively) impacted. The simulations also indicate that only the anchovy fleet, due to removal of larger fishes preying on small pelagics, would gain from increased fishing, while the other fleet would either maintain their catches or suffer slight decreases.

Ecopath with Ecosim also includes routines for optimization of fishing effort based on various constraints. It can be used to identify the fleet configuration which maximizes (1) net economic value (rent of the fishery), (2) social value (employment), (3) the rebuilding of specific stocks (mandated rebuilding) or (4) ecosystem structure (high biomass of long-lived ecosystem groups). Running the optimization routine with default parameter settings in Ecosim and with an assumption that the costs of fishing amounted to 95% of the value of the fishery (for each of the five fleets included in

the analysis), gives the results summarized in Table 8.

This indicates that considerable economic benefit (more than a doubling of the rent) could be obtained by scaling down the effort of the anchovy, pelagic and demersal fleets, while maintaining the prawn and shellfish fleet effort. However this would come at a price of 30% lower employment in the sector. The results are however very dependent on the assumptions made about the cost of fishing and employment by sector – assumptions about which we have little information at present – in addition to the uncertainty associated with the underlying Ecopath parameters. We do, however, believe that this type of analysis is of direct relevance to future management of the fisheries. It also draws attention to the additional research and data needed to conduct such analyses.

Conclusion

There is a vast amount of information available about aquatic ecosystems and resources, and any attempt to model marine ecosystems should benefit from this. Here this is done through analysis of catch and survey information, combined with extensive literature searches. A major source of information is the FishBase database (www.fishbase.org), which includes a specific search routine for Ecopath modeling. This can be used to extract published information that may be available for fishes occurring in a given area. It should be clear, however, that published information should always be supplemented by local knowledge or research inputs. For the West Coast of Peninsular Malaysia, the main gaps in knowledge with regards to the Ecopath model relates to aspects of food and feeding. At present, with the lack of such information, the ecosystem analysis relies heavily on information from other areas. This information, although from similar ecosystems, is probably less reliable than if local information were obtained.

Table 7. Results from a preliminary time-dynamic simulation using Ecosim for the West Coast of Peninsular Malaysia ecosystem. The table presents the catches (as % of their 1991 level) that would result from lowering fishing effort to 20% of the 1991 baseline level, compared with the catches resulting from a doubling of the baseline effort.

Fleet	Catch (as % of 1991 baseline)	
	20% effort	200% effort
Anchovy	22	172
Pelagic fishes	109	87
Demersal fishes and prawns	101	99
Prawn	100	101
Shellfish	100	100

Table 8. Results from optimization of economic rent of the fisheries of the West Coast of Peninsular Malaysia. Estimates are presented relative to the effort in the 1991 Ecopath model. (See text.)

Economic rent (%)	Employment (%)	Anchovy fleet effort (%)	Pelagic fleet effort (%)	Demersal fleet effort (%)	Prawn fleet effort (%)	Shellfish fleet effort (%)
263	71	63	67	55	99	101

Another possible improvement is to refine the ecosystem model through more detailed spatial analysis. For example, the whole area could be broken down into two separate areas, the coastal and offshore areas. However, the total number of boxes (trophic groups) would have to be increased accordingly so that the system would reflect the real interaction between species, area and size. This can only be done reliably based on information from each area, especially on the diet composition of the various groups. However, with more information about spatial ecosystem dynamics, it would become possible to construct spatial dynamic models using the Ecospace module of Ecopath with Ecosim (Walter et al. 1999).

Thus, we conclude that in order for management issues to be addressed confidently using simulation modeling, it is necessary to obtain more information on diet composition, as well as on the changes in fishing effort over time, and about bioeconomic aspects of the fishing fleets, notably of the cost of fishing.

References

- Alias, M. 1994. Prediction of catch and species composition from the West Coast of Peninsular Malaysia. Unpublished, Fisheries Research Institute, Penang, Malaysia.
- Aliño, P.M., L.T. McManus, J.W. McManus, C.L. Nanola, M.D. Fortes, G.C. Trono and G.S. Jacinto. 1993. Initial parameter estimations of a coral reef flat ecosystem in Bolinao, Pangasinan, northwestern Philippines, p. 252 - 267, *In* V. Christensen and D. Pauly (eds.) Trophic models of aquatic ecosystems. ICLARM Conference Proceedings 26, 390 p., Manila, Philippines.
- Arreguin-Sanchez, F., E. Valero-Pacheco and E.A. Chavez. 1993. A trophic box model of the coastal fish communities of the southwestern Gulf of Mexico, p. 197 - 205. *In* V. Christensen and D. Pauly (eds.) Trophic models of aquatic ecosystems. ICLARM Conference Proceedings 26, p390.
- Chee, P.E. and others. 1998. Demersal fish resources survey within EEZ of Malaysia. Fisheries Research Institute (Unpublished).
- Choo, P.S., I. Ismail and H. Rosly. 1994. The West Coast of Peninsular Malaysia, p. 33 - 54. *In* S. Holmgren, ed. An environmental assessment of the Bay of Bengal Region. BOBP/REP/67, p 256. Bay of Bengal programme and Swedish Center for coastal Development and Management of Aquatic Resources, Madras, Madras, India.
- Christensen, V. and D. Pauly. 1992. A guide to the ECOPATH II software system (version 2.1). ICLARM Software 6. ICLARM, Manila, Philippines.
- Christensen, V., C.J. Walter and D. Pauly. 2000. Ecopath with Ecosim - A User's Guide Fisheries Centre, University of British Columbia, Vancouver, B.C. Canada. ICLARM, Penang, Malaysia.
- De La Cruz-Aguero, G. 1993. A preliminary model of Mandinga Lagoon, Veracruz, Mexico, p. 193 - 196. *In* V. Christensen and D. Pauly (eds.) Trophic models of aquatic ecosystems. ICLARM Conference Proceedings 26, p 390.
- DOF. 1992. Annual Fisheries Statistics 1991. Department of Fisheries, Ministry of Agricultural, Kuala Lumpur, Malaysia.
- FAO. 1997. FAO Yearbook. Fishery Statistics 84 : 708.
- Gong, W.K., J.E. Ong, C.H. Wong and G. Dhanarajah. 1980. Productivity of mangrove trees and its significance in a managed mangrove ecosystem in Malaysia. Asian Symposium on Mangrove Environmental Research and Management, University of Malaya and UNESCO. 25 - 29 August 1980, Kuala Lumpur, Malaysia.

- Hydrographic Department. Admiralty. 1964. Malacca Strait Pilot. 3rd Edition, London.
- Ichikawa, T. 1986. Particulate organic carbon in the water off the Terengganu coast, p. 87 - 92. *In* A. K. M. Mohsin, et al. (eds.) Ekspedisi Matahari '85: A study on the offshore waters of the Malaysian. Occasional Paper.3. Faculty of Fisheries and Marine Science, University Pertanian Malaysia, Selangor, Malaysia.
- Ichikawa, T. and A.T. Law. 1988. Particulate organic carbon of the south-eastern portion of the South China Sea, p. 37 - 42. *In* A. K. M. Mohsin and M. I. Mohamad, eds. Ekspedisi Matahari '87: A study on the offshore waters of the Malaysian EEZ, Vol. 8. Occasional Publication. 8. Faculty of Fisheries and Marine Science, University Pertanian Malaysia, Selangor, Malaysia.
- Kushairi, R. 1992. The areas and species distribution of seagrasses in Peninsular Malaysia. Paper presented at the 1st National Natural Resources Symposium, FSSA, Universiti Kebangsaan Malaysia, 23 - 26 July 1992, Kota Kinabalu, Sabah.
- Liew, H.C. and E.H. Chan. 1987. ECOPATH model of a tropical shallow-water community in Malaysia, p. 32. International Development Research Centre (Unpublished), Singapore.
- Lokman, S., B.K. Kamarul and S. Nasir. 1988. Chlorophyll a content off the Sarawak waters of the South China Sea, p. 87 - 90. *In* A. K. Mohsin, et al., eds. Ekspedisi Matahari'87: A study on the offshore waters of the Malaysian EEZ. Occasional Publication 8. Faculty of Fisheries and Marine Science, Universiti Pertanian Malaysia, Selangor, Malaysia.
- MCRST (Malaysian Coastal Resources Study Team). 1992. The coastal resources management plan for South Johore, Malaysia. ICLARM Technical Report 33. ICLARM. Ministry of Science, Technology and the Environment, Malaysia., Kuala Lumpur.
- Opitz, S. 1993. A quantitative model of the trophic interactions in a Caribbean coral reef ecosystem, p. 259 - 267. *In* V. Christensen and D. Pauly, eds. Trophic models of aquatic ecosystems. ICLARM Conference Proceedings 26, p 390.
- Pauly, D. 1984. Fish population dynamics in tropical waters: A manual for use with programmable calculators. ICLARM Studies and Reviews 8, Manila, Philippines.
- Pauly, D. and V. Christensen. 1993. Stratified models of large marine ecosystem: a general approach and an application to the South China Sea, p. 148 - 174. *In* K. Sherman, et al. (eds.) Large Marine ecosystems: stress, mitigation and sustainability. AAAS Press (American Association for the Advancement of Science publishing division), p 376, Washington, D.C., USA.
- Pauly, D., V. Sambilay, Jr and S. opitz. 1993. Estimates of relative food consumption by fish and invertebrate populations, required for modelling the Bolinao Reef Ecosystem, Philippines, p. 1 - 13. *In* V. Christensen and D. Pauly, eds. Trophic models of aquatic systems. ICLARM Conference Proceedings 26, 390 p., ICLARM, Manila, Philippines.
- Pauly, D., V. Christensen and C.J. Walter. 2000. Ecopath, Ecosim and Ecospace as tools for evaluating ecosystem impact of fisheries. *ICES Journal of Marine Science* 57 : 697 - 706.
- Polovina, J.J. 1984. Model of a coral reef ecosystem. I. The ECOPATH model and its application to French Frigate Shoals. *Coral Reefs* 3(1) : 1 - 11.
- Raihan, A., and T. Ichikawa. 1986. Chlorophyll a content off the Terengganu coast, p. 117 - 120. *In* A. K. M. Mohsin, et al. (eds.) Ekspedisi Matahari '85: A study on the offshore waters of the Malaysian EEZ. Occasional Publication Paper 3. Faculty of Fisheries and Marine Science, Universiti Pertanian Malaysia, Selangor, Malaysia.
- Silvestre, G., S. Selvanathan and A.H.M. Salleh. 1993. Preliminary trophic model of the coastal fisheries resources of Brunei Darussalam, South China Sea, p. 300 - 306. *In* V. Christensen and D. Pauly (eds.) Trophic models of aquatic ecosystems. ICLARM Conference Proceedings 26, 390 p., Manila, Philippines.
- Vega-Cendejas, M.E., F. Arreguin-Sanchez and M. Hernandez. 1993. Trophic fluxes on the Campeche Bank, Mexico, p. 206 - 213, *In* V. Christensen and D. Pauly (eds.) Trophic models of aquatic ecosystems. ICLARM Conference Proceedings 26, p 390.
- Walter, C.J., V. Christensen and D. Pauly. 1997. Structuring dynamic models of exploited ecosystems from trophic mass-balance assessments. *Reviews in Fish Biology and Fisheries* 7 : 139 - 172.
- Walter, C.J., D. Pauly and V. Christensen. 1999. Ecospace: Prediction of mesoscale spatial patterns in trophic relationships of exploited ecosystems, with emphasis on the impacts of marine protected areas. *Ecosystems* 2 : 539 - 554.

Appendix A. Landings (from catch statistics), biomass (from trawl surveys), Production/Biomass ratio (P/B) and Consumption/Biomass (Q/B) of marine aquatic animals and plants used in modeling the West Coast of Peninsular Malaysia fisheries ecosystem 1991.

Assemblage	Landings (t·km ⁻² ·year ⁻¹)			Biomass (t·km ⁻²)			P/B ^a (year ⁻¹)			Q/B ^b (year ⁻¹)
	Coastal	Offshore	Both	Coastal	Offshore	Both	Coastal	Offshore	Both	
Area, km²	231 76.2	466 76.3	698 52.5	231 76.2	466 76.3	698 52.5	231 76.2	466 76.3	698 52.5	69 852.5
Ecological Group										
Crustacean (excl. plankton)	2.45	0.01	0.82	0.72	<0.01	0.24	5.11	5.11	5.11	21.81
Intermediate predators	5.82	1.95	3.23	0.49	0.59	0.56	13.61	4.98	7.49	11.06
Large pelagics	1.23	0.40	0.67	0.55	0.18	0.30	3.93	3.93	3.93	9.55
Large predators	0.05	0.02	0.03	0.03	0.02	0.02	3.38	2.55	2.86	7.30
Small demersal prey species	0.36	0.04	0.14	0.03	<0.01	0.01	13.39	13.76	13.45	23.74
Small pelagics	0.20	0.09	0.13	0.09	0.05	0.06	4.07	3.49	3.75	12.90
Squids and cuttlefishes	0.47	0.20	0.3	0.23	0.10	0.14	4.11	4.09	4.10	10.51
Zooplankton	0.55	0.00	0.18	2.16	0.86	1.29	67.00	67.00	67.00	280.00 ^b
TOTAL	11.70	2.80	5.75	4.49	1.97	2.80	–	–	–	–

Note: ^a P/B values from (Silvestre et al. 1993)

^b Q/B values estimated from Appendix B.

Appendix B. Consumption/biomass ratio (Q/B) obtained from selected references.

Ecological group	Taxa	Q/B (year ⁻¹)	Sources
Crustacean (excl. plankton)	Crabs	8.50	De La Cruz-Aguero (1993)
	Banana prawn	37.90	Arreguin-Sanchez et al. (1993)
	Shrimps	19.00	De La Cruz-Aguero (1993)
	Misc. marine crustaceans	28.94 28.00	Pauly et al. (1993) Aliño et al. (1993)
Intermediate predators	Bombay duck, Lizard fish	4.27	Pauly et al. (1993)
		8.30	Arreguin-Sanchez et al. (1993)
	Catfish eel	10.00	Arreguin-Sanchez et al. (1993)
	Catfishes	10.00	De La Cruz-Aguero (1993)
	Grouper	2.04	Pauly et al. (1993)
		4.00	Aliño et al. (1993)
		4.60	Arreguin-Sanchez et al. (1993)
	Mangrove snapper	4.89	Pauly et al. (1993)
	Marine catfish	10.00	Arreguin-Sanchez et al. (1993)
	Mojarras/Silver biddies	15.30	Arreguin-Sanchez et al. (1993)
	Parrotfish	28.00	Aliño et al. (1993)
	Rabbitfish/Spinefeet	47.92	Pauly et al. (1993)
	Red snapper	4.40	Arreguin-Sanchez et al. (1993)
	Snappers	4.70	De La Cruz-Aguero (1993)
Wrasse, hogfish	7.55	Aliño et al. (1993)	

Appendix B. Consumption/biomass ratio (Q/B) obtained from selected references. (continued)

Ecological group	Taxa	Q/B (year⁻¹)	Sources
Large pelagics	Spanish mackerel/ King mackerel	8.90	Vega-Cendejas et al. (1993)
		10.20	Arreguin-Sanchez et al. (1993)
Large predators	Conger eel, Moray eel Barracuda Large sharks Shark	6.50	Aliño et al. (1993)
		10.00	Arreguin-Sanchez et al. (1993)
		4.90	Opitz (1993)
		7.80	Arreguin-Sanchez et al. (1993)
Large zoobenthos feeders	Large rays Rays	4.90	Opitz (1993)
		10.80	De La Cruz-Aguero (1993)
Medium pelagics	Amberjack Jacks	10.00	Arreguin-Sanchez et al. (1993)
		10.00	De La Cruz-Aguero (1993)
Misc. invertebrates	Misc. marine molluscs	5.60	Aliño et al. (1993)
		8.30	Arreguin-Sanchez et al. (1993)
		8.60	Vega-Cendejas et al. (1993)
	See cucumbers nei	3.83	Pauly et al. (1993)
		22.25	Aliño et al. (1993)
	Sea-urchins	3.58	Pauly et al. (1993)
25.00	Aliño et al. (1993)		
Small demersal prey species	Flatfish Flatfishes Tonguefish/tongue sole	9.10	Arreguin-Sanchez et al. (1993)
		9.10	De La Cruz-Aguero (1993)
		9.10	Arreguin-Sanchez et al. (1993)
	Cardinalfishes Damsel fishes Drums and croakers Gobies Mojarras	28.29	Pauly et al. (1993)
		19.39	Aliño et al. (1993)
		54.70	Aliño et al. (1993)
		10.00	De La Cruz-Aguero (1993)
		12.30	De La Cruz-Aguero (1993)
		70.09	Aliño et al. (1993)
		15.30	De La Cruz-Aguero (1993)
Small pelagics	Mulletts Needlefishes Anchovy Fringescale sardinella Herrings Chub mackerels	12.30	De La Cruz-Aguero (1993)
		7.20	De La Cruz-Aguero (1993)
		19.70	Arreguin-Sanchez et al. (1993)
		11.70	Arreguin-Sanchez et al. (1993)
		11.70	De La Cruz-Aguero (1993)
		14.82	Pauly et al. (1993)
Squids and cuttlefishes	Common squid Octopus Squids	8.30	Arreguin-Sanchez et al. (1993)
		8.60	Vega-Cendejas et al. (1993)
		7.30	Pauly et al. (1993)
		11.70	Opitz (1993)
		16.64	Pauly et al. (1993)
Turtles	Green turtles	3.50	Polovina (1984)
Zooplankton	Zooplankton Sergestid shrimp Zooplankton	120	De La Cruz-Aguero (1993)
		24.60	Arreguin-Sanchez et al. (1993)
		119.70	Arreguin-Sanchez et al. (1993)
		133.33	Aliño et al. (1993)

Appendix C. Annual landings (t) by type of fish from the West Coast of Peninsular Malaysia.

Code No	Common Name	Local Name	Year																											
			69	70	71	72	73	74	75	76	77	78	79	80	81	82	83	84	85	86	87	88	91	92	93	94	95	96	97	98
24	1 Chacunda Gizzard Shad	Kebasi	558	611	495	676	754	527	888	640	636	1760	966	1249	1175	1362	1538	1555	3018	3354	2472	2195	2364	3140	3171	2435	2633	2842	2609	2776
24	2 Shad, Elongate Ilisha	Puput	310	444	704	886	691	677	440	617	565	729	562	857	429	716	1071	1508	3563	3105	3520	4620	4432	4950	4802	5522	6225	7468	6563	11497
24	3 Shad	Terubuk	2	13	15	-	-	0	4	35	14	18	12	0	12	15	13	2	6	22	1	-	49	41	1	0	45	17	30	107
25	1 Barramundi (=Giant Seaperch)	Siakap	-	-	-	-	-	-	-	36	71	126	299	205	44	98	143	80	123	112	66	50	34	48	30	61	73	89	82	72
31	3 Tongue Soles	Lidah/ Sebelah	403	430	532	502	611	866	1262	2509	2189	3028	2969	2799	2538	2902	2004	2808	3224	2927	3541	1701	1459	2249	1960	2387	2735	3053	2918	2834
33	1 Parrot Fishes	Bayan	-	-	-	-	-	-	1	6	5	2	-	-	-	-	-	-	29	13	1	2	-	1	-	0	3	10	8	13
33	2 Goatfishes	Biji Nangka	633	667	399	410	506	1610	1745	2110	2324	1899	596	593	404	300	336	322	596	583	1323	1345	2570	2633	2148	2523	1958	2139	1435	983
33	3 Spotted Sicklefish	Daun Bahau	92	52	62	284	282	221	232	215	129	146	84	43	20	18	65	120	53	318	303	269	94	92	158	87	67	82	90	140
33	4 Fusilie	Delah	2	-	8	37	-	81	31	37	2	232	22	38	75	29	116	28	62	98	19	35	11	5	6	51	5	23	57	35
33	5 Catfishes	Duni	4117	3860	3036	3266	2964	2223	1791	2582	2358	3033	2863	2434	2448	2658	3173	3063	2694	3274	2621	3326	3749	3656	3404	3393	4285	5265	5131	5839
33	6 Spinefoot	Denggis	-	11	7	7	4	128	2	17	13	1	21	35	17	5	103	26	89	371	143	212	107	193	203	173	134	106	91	96
33	7 Croakers	Gelama	3546	2729	2443	2896	3791	4263	4375	6958	8435	6321	6116	5387	5029	6825	7576	8485	10271	-	9354	9111	7084	8257	8072	10260	10631	11070	11590	13305
33	8 Silver Grouper	Gerut	489	546	508	750	572	721	718	989	884	1663	1346	988	1334	1190	869	735	893	794	794	790	734	560	489	456	501	475	354	647
33	9 John's Snapper	Jenahak	727	413	479	752	790	589	558	537	771	1127	1585	958	725	778	1444	727	926	1213	847	914	643	567	497	619	496	434	451	484
33	10 Grouper/Sweetlips	Kaci	-	-	-	2	1	26	34	171	82	569	647	147	124	162	20	95	62	109	136	155	60	64	56	68	139	57	43	26
33	11 Grouper	Kerapu	1019	906	985	1371	1231	900	860	991	1156	1662	3504	1631	152	1823	1894	1619	1454	1583	2101	2811	1829	1996	2154	2391	2166	1765	1593	1629
33	13 Threadfin Breams	Kerisi	1688	1077	799	823	953	1072	842	991	2681	4919	5577	5321	5524	6649	5333	6209	3908	3486	9902	7765	8527	12231	10197	9240	10886	9272	13291	10458
33	13 Crimson Jobfish	Kerisi Bali	-	-	-	-	-	-	-	-	13	-	486	420	141	170	421	448	272	449	501	743	656	521	446	488	474	426	320	190
33	14 Pony Fishes	Kilek	321	162	193	304	108	354	448	194	556	229	341	260	130	258	190	412	345	507	649	570	347	51	96	84	164	85	95	158
33	15 Daggetooth Pike Conger	Malong	622	672	688	602	666	786	904	1803	1419	2013	2176	1990	1698	2286	1589	1972	1433	1497	2379	2027	1612	1506	1468	1505	1635	1733	1751	2550
33	16 Red Snapper	Merah	3797	3247	2976	3185	2393	1259	907	1084	1163	1861	3136	1819	1447	1491	2546	1087	917	1253	1825	2091	1437	1609	1125	648	614	615	337	318
33	17 Greater Lizardfish	Mengkerong	-	530	201	341	567	1339	1667	1187	3472	5649	2017	1342	1204	1562	1337	1058	884	1255	3268	2605	2849	3826	4143	3702	4521	5469	5945	7114
33	18 Bigeye Snapper	Remong	-	-	-	-	-	1	0	56	524	11	84	162	115	172	74	76	150	188	436	494	248	508	446	181	286	234	138	127
33	19 Ed Catfish	Semilang	596	452	278	200	131	191	216	330	411	664	636	777	941	1366	1466	820	850	1615	819	582	826	1294	707	700	916	915	1086	861
33	20 False Trevally	Shrubu	441	176	187	274	70	23	34	115	26	11	-	-	0	0	0	-	-	-	4	-	-	-	251	207	1202	112	25	3

Appendix C. Annual landings (t) by type of fish from the West Coast of Peninsular Malaysia. (continued)

Code No	Common Name	Local Name	Year																											
			69	70	71	72	73	74	75	76	77	78	79	80	81	82	83	84	85	86	87	88	91	92	93	94	95	96	97	98
33	21 Silver Sillago	Bulus	-	-	-	-	-	331	180	286	436	257	84	278	276	404	573	448	353	386	302	215	349	773	781	1167	1178	1195	1050	902
33	22 Monocle Bream	Pasir	-	-	-	-	-	-	-	-	-	-	-	-	-	-	-	-	36	121	68	24	19	37	16	21	3	1	2	1
34	1 Barracuda	Alu-Alu	428	212	304	375	389	636	791	975	651	3299	1158	1345	1084	1091	950	862	979	1125	1488	1460	1504	1249	1334	1036	895	816	875	
34	2 Cobia	Aruan Tasek	10	4	6	6	6	47	161	297	222	198	109	223	137	223	100	85	66	140	162	114	112	117	117	164	131	122	70	83
34	3 Pomfret	Bawal	2331	2450	1813	1764	1633	1997	2104	2005	2533	2897	3885	3720	3819	4006	5701	3242	4265	4811	4771	4897	3868	5138	4071	4884	4631	5841	6748	6167
34	4 Mullet	Belanak	2882	1865	1461	702	382	495	432	513	376	913	1476	2877	4185	4494	3385	2662	4363	4550	1928	1830	1675	2070	1663	1391	1481	1641	3182	3465
34	5 Trevally	Cermin	277	223	278	546	473	253	395	586	110	320	361	213	66	195	182	175	129	343	773	467	520	202	277	327	244	222	381	246
34	6 Torpedo Scad	Cincaru	6015	6865	6115	3223	4678	7836	3475	5597	3263	7644	9244	8224	3746	4896	10460	12407	4340	3787	3887	4764	3841	3061	4644	4459	4724	9670	13164	8523
34	7 Silvermouth Trevally	Demudok	-	-	-	-	-	236	258	256	30	27	763	1071	622	619	1086	930	787	1167	2176	2426	1791	1998	1552	1064	771	594	666	556
34	8 Blackhand Paradise Fish	Kurau	949	837	469	643	609	637	701	1005	1386	1757	941	1193	1676	1871	1920	1144	778	857	734	866	804	857	954	1129	1272	1265	1200	1459
34	9 Scads	Pelata/Selar	1399	956	842	1457	884	520	728	1274	1687	4900	3459	4335	3236	3516	3915	4390	3254	3192	7641	6860	4615	4405	2868	2848	3844	5811	7045	5825
34	10 Yellowstrip Scad	Selar Kuning	28	20	67	134	168	210	448	862	884	3048	2283	1179	2546	2186	2228	2840	1242	1929	2331	2576	2966	3041	2749	2709	2946	3726	2947	3662
34	11 Shortfin Scad	Selayang	3578	3681	2309	1814	4849	7021	5332	3695	6398	6025	6599	7459	8194	9408	11358	10275	4209	5334	13612	10882	13609	15558	6641	6969	10507	9979	10392	8748
34	12 Rainbow Runner	Pisang-Pisang	-	-	-	-	-	26	111	1151	360	324	359	321	177	89	56	86	1	90	606	56	183	188	507	232	262	479	470	262
34	13 Leatherkin	Talang	191	69	58	48	54	349	55	55	126	62	157	502	461	640	485	597	726	513	487	628	546	442	528	449	579	564	324	471
35	1 Anchovies	Bilis	18874	22098	22647	15654	20281	10369	9719	10072	11653	14882	34270	28113	27357	33425	27410	19799	13955	13166	17175	25325	26223	25469	14891	28260	12802	11982	13729	13791
35	2 Dorab Wolf-Herring	Parang	3220	3327	3520	3034	3189	3281	3009	3700	4047	4861	3200	2553	3161	3360	3558	2625	2868	3338	4301	3159	2802	2326	2554	2850	2449	2307	1902	1893
35	3 Sardines	Tamban	2547	3504	3003	2080	3770	5776	4060	10217	9833	5240	4867	6831	5244	6297	7619	5281	3403	3135	6959	6326	4020	5004	5733	5521	5023	3853	3541	4503
35	4 Indo-Pacific Tarpon	Bulan	-	-	-	-	-	-	15	4	3	90	-	-	-	-	-	2	9	16	4	6	4	-	2	1	7	8	7	6
36	1 Tuna	Aya	1333	2492	1740	1992	1002	1590	2590	1712	2344	3190	2024	4701	2632	1713	2680	3075	4551	4036	6719	5035	3666	4626	5051	8194	5460	2939	3727	6178
36	2 Marlin	Mersuji	22	49	53	43	202	208	-	-	0	-	44	70	49	76	120	73	138	93	6	-	-	-	1	0	0	2	3	0
37	1 Short Mackereel	Kembong	57310	29122	33953	9762	21693	12313	9987	12414	19570	23803	34153	51800	45027	54719	62594	68966	58503	31581	56193	40059	42986	55285	35380	46066	36104	63771	101003	73781
37	2 Spanish Mackerel	Tenggiri	2987	3607	4340	4015	3435	3985	3169	3269	4338	4728	5376	4869	5151	6694	5170	3138	3970	5703	7623	4933	3813	4255	4608	5665	4411	5222	3767	3886
37	3 Largehead Hairtail	Timah	793	676	410	586	1166	1619	1221	2344	2563	2291	1439	2607	1529	829	767	1266	2180	1694	3084	5066	2087	1598	1961	6243	4123	2862	2899	2759
38	1 Rays	Pari	1697	1921	1932	1522	1638	1258	1543	2343	2638	3097	3205	3256	2456	2767	3063	3167	2921	3623	4672	6126	4391	1015	759	776	694	769	962	970
38	2 Sharks	Yu	996	849	743	957	946	778	872	1800	2142	2229	1644	1420	1003	1068	628	979	972	1080	906	1359	1015	759	776	694	769	962	970	
39	1 Trash Fish	Ikan Baja	39968	43989	58779	68010	94829	118632	103920	100610	135324	123892	123511	124103	135192	117175	122368	89281	97386	111323	188121	145510	179365	192576	141794	151448	156841	160560	186274	171087
39	2 Mixed Fish	Ikan Campur	10686	8765	9136	8559	10668	8692	8718	7484	5993	7316	7553	4947	4020	6766	8140	9772	8546	7600	10694	9984	10628	15605	13741	9394	9417	9942	13394	14479
39	3 Starry Triggerfish	Jebong	-	-	-	-	-	-	58	18	348	206	279	304	200	168	511	536	343	260	747	1511	793	1433	1916	1164	1571	501	546	721
42	1 Crab	Ketam	2477	1679	1482	1300	1841	1739	2200	3120	3864	3914	3254	2877	2997	4193	4085	3610	3275	3578	3156	2989	3652	3505	3231	3892	3703	3751	4226	3900
45	1 Lobster	Udang Karang	-	-	-	-	-	-	-	-	-	-	-	-	2	2	-	15	42	64	38	177	31	57	31	24	27	33	20	15
45	2 Big Prawn	Udang Besar	-	-	-	-	-	-	-	-	-	-	6397	5578	4047	5061	5120	-	-	-	-	-	-	-	-	-	-	-	-	-

Appendix C. Annual landings (t) by type of fish from the West Coast of Peninsular Malaysia. (continued)

Code No	Common Name	Local Name	Year																																	
			69	70	71	72	73	74	75	76	77	78	79	80	81	82	83	84	85	86	87	88	91	92	93	94	95	96	97	98						
45	3 Medium Prawn	Udang Sedang	-	-	-	-	-	-	-	-	-	21747	16581	14250	14576	16064	-	-	-	-	-	-	-	-	-	-	-	-	-	-	-	-				
45	4 Small Prawn	Udang Kecil	-	-	-	-	-	-	-	-	-	28540	28922	27224	32896	29337	-	-	-	-	-	-	-	-	-	-	-	-	-	-	-	-				
45	5 Banana Prawn	Udang Putih	-	-	-	-	-	-	-	-	-	-	-	-	-	-	6210	6781	6796	5236	2830	3522	3800	3320	-	-	-	-	-	6573	8019					
45	6 Greasyback Prawn	Udang Minyak	-	-	-	-	-	-	-	-	-	-	-	-	-	-	11279	12630	14917	16108	17002	18487	18550	18390	-	-	-	-	-	11177	11079					
45	7 Pink Prawn	Udang Merah Ros	-	-	-	-	-	-	-	-	-	-	-	-	-	-	5874	8224	5935	2690	356	301	1276	1390	-	-	-	-	-	3774	2859					
45	8 Rainbow Prawn	Udang Kulit Keras	-	-	-	-	-	-	-	-	-	-	-	-	-	-	3941	2754	1762	2567	2237	2487	2935	2977	-	-	-	-	-	2755	2553					
45	9 Tiger Prawn	Udang Harimau	-	-	-	-	-	-	-	-	-	-	-	-	-	-	-	551	384	368	330	244	228	112	-	-	-	-	-	119	204					
45	10 Other Prawn	Lain-lain Udang	-	-	-	-	-	-	-	-	-	-	-	-	-	-	11526	13086	15812	25953	31292	-	-	27668	-	-	-	-	-	23356	24913					
45	11 Other Prawn/ Sergestid Prawn	Lain-lain Udang/ Udang Baring	-	-	-	-	-	-	-	-	-	-	-	-	-	-	-	-	-	-	-	-	-	-	-	-	-	-	-	-	-	-				
45	12 Penaeid Prawn	Udang Penaeid	30148	40981	46703	36962	45575	48647	37967	43581	50987	63017	-	-	-	-	-	-	-	-	-	-	-	-	-	-	-	-	-	-	-	-				
45	13 Sergestid Shrimp	Udang Baring	6866	5392	4886	16072	6000	7501	9137	8181	10615	10672	7131	9299	13267	5074	9895	12139	9807	8997	9214	13009	-	12737	0	17310	16864	14449	14449	17399	-	-				
45	14 Lobsters/Penaeid Prawn	Udang Karang/ Penaeid	-	-	-	-	-	-	-	-	-	-	-	-	-	-	-	-	-	-	-	-	-	-	-	-	-	-	-	-	-	-	-	-		
45	15 Penaeid Prawn/ Sergestid Shrimp	Udang Penaeid/ Baring	-	-	-	-	-	-	-	-	-	-	-	-	-	-	-	-	-	-	-	-	-	-	-	-	-	-	-	-	-	-	-	-	-	
45	16 Giant Freshwater Prawn	Udang Calah	-	41	63	-	-	-	-	-	-	-	-	-	-	-	-	-	-	-	-	-	-	-	-	-	-	-	-	-	-	-	-	-	-	
56	1 Shell	Siput	619	673	743	383	252	68	5000	653	2099	499	1186	2121	2231	7353	5830	4333	2620	818	20467	1529	782	4475	1161	7730	18424	8696	15275	17772	-	-	-			
57	1 Octopus	Sotong Kereta	-	-	-	-	-	-	-	-	-	-	379	444	347	413	216	168	136	115	244	209	386	505	202	466	223	304	476	663	-	-	-			
57	2 Bobbins Squid	Sotong Katak	-	-	-	-	-	-	-	-	-	-	-	-	-	-	-	-	-	-	-	-	-	-	-	-	-	-	-	-	-	-	-	-	-	
57	3 Squid	Sotong Biasa	-	-	-	-	-	-	-	-	-	-	-	-	-	-	-	-	-	-	-	-	-	-	-	-	-	-	-	-	-	-	-	-	-	-
57	4 Cephalopods	Sotong Kereta/Katak/ Biasa	1365	2119	1746	1526	2104	4010	5311	8616	11583	11778	-	-	-	-	-	-	-	-	-	-	-	-	-	-	-	-	-	-	-	-	-	-	-	
76	1 Jellyfish	Obor-Obor	-	-	-	-	-	-	-	-	-	-	-	-	-	-	-	-	-	-	-	-	-	-	-	-	-	-	-	-	-	-	-	-	-	-
TOTAL			219359	205464	224590	200737	249801	267917	241662	262940	331441	355172	369114	372404	364514	384642	403998	347742	327124	324047	499862	430189	489334	510471	401900	474006	446516	460302	546818	518525	-	-	-	-		

