

This issue of *Fishbyte* is taken up almost entirely by a paper by Villy Christensen and myself. My excuses for this (ab)use of editorial privilege are two:

- (i) the topic of that paper is well in line with the main theme of this issue of *Naga* - sustainability - and how to conduct research about it; and
- (ii) this article both launches a new project, aimed at modeling the world ocean, and a new tool for doing it, Version 3.0 of ECOPATH II.

Villy Christensen and I hope that the invitation in this article, for colleagues to join us in this global modelling effort, will be picked up by numerous NTFS members, and other readers of *Fishbyte*, and that *Fishbyte* itself will thus become a privileged forum for discussing the progress of this project.

The two additional papers that managed to get squeezed into this issue of *Fishbyte* also deal with the theme of sustainability: W. Hertlein

shows how modeling can be used to simulate the mechanisms which allow a small pelagic species - here the Peruvian anchoveta *Engraulis ringens* - to maintain itself in its highly fluctuating habitat. That habitat incidentally—the cold upwelled waters off Peru and Chile—may be expanding, as predicted by Bakun (1990, Global climate change and the intensification of coastal upwelling. *Science* 247:198-201) as a slightly paradoxical result of global *warming*. Hence anchoveta may have a future in at least the early part of the “late holocene”, despite their schooling habits (see Parrish, p. 7). In any case, catches of anchoveta have increased dramatically in recent years.

However, C. Garcia and O. Salono show that the future may be grim for *Tarpon atlanticus*, certainly so along the Caribbean coast of Colombia.

Whether large fish such as this will survive Parrish’s scenario for the late holocene is still open. Our job as fisheries scientists is to keep such options open as long as we can. **D. Pauly**

Fish Production, Catches and the Carrying Capacity of the World Oceans

VILLY CHRISTENSEN
DANIEL PAULY
ICLARM

Abstract

A brief review of the status of the world fisheries is presented with emphasis on the differences between catches, (= landings + bycatch), biological production of fish, and predation (= production - catches). The ECOPATH II approach, implemented as a new, Windows-based software is then shown to allow construction of a stratified world model accounting for global catches, production of and predation on fishes, and thus improved estimates of global potentials. A newly initiated, cooperative project is described through which the foundation for such a global model could be constructed, based on a stratified database with more than 100 trophic models. Collaborators are invited to join in this, and will be assisted in constructing models covering their areas of interest.

Introduction

Fish production, catches ... Wait! Isn't that the same? For biologists, it's not; but the terms are often used as synonyms since the processing industry turns catches into fish products. Our interest

here, however, is in the processes in the sea: how much we extract (= the catches), and how much is actually produced, and then consumed by predators, which thus compete with the fisheries.

One of the earliest expressions of the relationship between production and catches in fully exploited stock is by Graham and Edwards (1962) who guessed that “properly harvested, it is reasonable to suggest that [fish stocks] may yield 50% by weight, at least, of the net annual production”.

Ryther (1969) used this 50% figure as well, albeit implicitly, but it is in the form of “Gulland’s equation” for estimation of potential yield that Graham and Edwards’ 50% guess became most famous. The equation (actually proposed by Alverson and Pereyra 1969) states that

$$\text{Potential yield} = 0.5 \cdot B_0 \quad \dots 1)$$

where B_0 is the unexploited biomass, and M is assumed equal to optimum fishing mortality, i.e., to the level of fishing generating the fabled Maximum Sustainable Yield (F_{MSY}).

Members Write

Mr. B. Ahilan, Assistant Professor, Department of Fisheries Extension, Fisheries College, Tamil Nadu Veterinary and Animal Sciences University, Tuticorin 628 008, India.

I am doing a Ph.D. program in Fisheries Science (area of specialization in aquaculture).

I have taken up research work in the maturation and breeding of goldfish *Carassius auratus*. For this purpose, I require literature and related information on maturation, induced breeding and growth of goldfish. Hence, I request you to kindly send me relevant literature.

This will be of immense use for me to pursue my research program. I will be grateful to you for this favor. Thanking you with kind regards.

Thesis Abstracts

Modelling Studies of Fish Production in Integrated Agriculture-Aquaculture Systems*

ANNE A. VAN DAM

The general objective of this thesis is to formulate a general model for fish production in integrated ponds and ricefields as a means of obtaining a better understanding of these production systems. Integrated culture systems produce fish without large industrial energy inputs and have positive effects on the whole farm system. A main characteristic is their environmental variability, notably dissolved oxygen concentration and temperature. A systems approach using mathematical models is advocated because it can lead to insights that have universal applicability while avoiding the pitfalls of site- and species-specific, expensive experimental work. Two modelling approaches are distinguished: descriptive models, generally the result of statistical analysis of datasets; and explanatory models, based on knowledge of the biological processes underlying fish production.

Multiple regression analysis (a descriptive modelling technique) was used for the analysis of data from 15 integrated rice-fish production experiments with the Nile tilapia (*Oreochromis niloticus* L.) in the Philippines. Results showed that this technique led to insights that had not been obtained through separate analysis of the experiments. The main drawback of this method was that the models were not applicable to other production environments.

An explanatory model (called Fish Growth Simulator, or FGS) for growth of *O. niloticus* was developed on the basis of an existing simulation model for the African catfish *Clarias gariepinus* Burchell (1822). After parameterization and calibration, the model gave good predictions of fish growth in independent datasets. Parameterization and calibration of the same model for the rainbow trout *Oncorhynchus mykiss* (Walbaum) demonstrated the generality of the model and it was concluded that, provided that enough data are available, the model may be used to predict growth in a wide range of fish species. Food amount and composition, and temperature were the environmental variables upon which the model based its predictions.

FGS was expanded with a dissolved oxygen module to accommodate oxygen as an environmental variable. The module was based on the hypothesis that oxygen is

needed in sufficient amounts for aerobic metabolism, and that gill surface area limits the supply of oxygen to fish. The resulting model allowed the simulation of fish growth under low dissolved oxygen concentration and also provided an explanation for differences in the final weight of fishes, both within and between species.

FGS was used for simulation of food and oxygen limitations in waste-fed fishponds in Honduras, Thailand and Rwanda. The model simulated fish growth for various combinations of environmental conditions: temperature, food availability and dissolved oxygen concentration. Validation, using data from Indonesia and Panama, was not successful because estimates of the food consumption rate in these countries were not reliable.

Methodology, the role of oxygen in fish metabolism and growth, implications of the models for the management of integrated agriculture-aquaculture systems and further work are also discussed.

* Accepted on 10 May 1995 for a Ph.D. degree in Agricultural and Environmental Science at the Wageningen Agricultural University, Wageningen, The Netherlands. Dr. A.A. van Dam's current address is: Department of Fish Culture and Fisheries, Wageningen Agricultural University, PO Box 338, 6700 AH Wageningen, The Netherlands.

On the Nutritional and Reproductive Cycles of Mullet, *Liza dussumieri* (Val.) and *Mugil cephalus* L. of Muthupet Saline Swamp, Tamil Nadu in the Context of Aquaculture*

P.R. BASKARAN

A comparison of the biology of the two mullet species inhabiting the Muthupet saline swamp illustrates the concept of niche segregation; not only the spatial and func-

tional niche but also the hypervolume or multidimensional niche. *Liza dussumieri* is the smaller fish and *Mugil cephalus* is relatively large. The life span of *L. dussumieri* has been calculated to be three years whereas that of *M. cephalus* is four years. Males were more dominant than females in both species. *L. dussumieri* was found to be a semi-annual breeder, with the breeding season extending from August to September and December to February. *M. cephalus* was found to breed during the post monsoon period (January to February/March) with an annual cycle. *L. dussumieri* appears to reach sexual maturity at a relatively small size and lesser age than *M. cephalus*. Both species eat mainly vegetable matter. *L. dussumieri* had a high level of feeding intensity once a year plus a moderate feeding intensity at another time of the year. *M. cephalus* had several fortnights of intense feeding, with other mod-

erate feeding levels throughout the year and breaks in between. In *L. dussumieri* muscles appeared to function as the storage organ more than the liver, but in *M. cephalus* for the buildup of the gonads, the liver seemed to contribute more than the muscles. Environmental parameters are said to influence events in reproductive and nutritional cycles and the fishes themselves choose a suitable period for reproduction by intrinsic mechanisms so that the new generation encounters a suitable environment.

*Edited abstract of the thesis submitted for a Ph.D. Degree to the Dept. of Animal Science, Bharathidasan University, Tiruchirappalli 620024, Tamil Nadu, India and awarded as 'Highly Commended' on July 1994. Further details may be obtained from the author.

Congratulations to Dr. Anne Van Dam

Dr. Anne van Dam, who has worked with ICLARM and its collaborators in Malawi and the Philippines, successfully defended his thesis on May 10th. He was also awarded the Wageningen Institute of Animal Sciences Ph.D. Students Publication Prize for his paper "Simulation of the effects of oxygen on food consumption and growth of Nile tilapia", co-authored with Dr. Daniel Pauly and now in press in *Aquaculture Research* Volume 26, 1995. The Abstract of Anne's thesis is given on p. 33 along with his current address in the Netherlands.

Erratum

Jimmie J. Mandima, author of the article "Socioeconomic Factors that Influence the Adoption of Small Scale Rural Fish Farming at Household Level in Zimbabwe", published in *Naga, the ICLARM Quarterly* 18(2):25-29 (April 1995), is a Research Fellow at the University Lake Kariba Research Station, University of Zimbabwe, PO Box 48, Kariba, Zimbabwe. Our apologies to the author for inadvertently missing out his affiliation and address.

Given that biological production can be defined as $P = Z \cdot B$ (Allen 1971) and that $Z = M + F$, setting $F_{MSY} = M$ implies the 50% rule.

The evolution of this and similar guesses are reviewed in Pauly (in press); Fig. 1 shows some of the estimates of global potential catch obtained using these guesses.

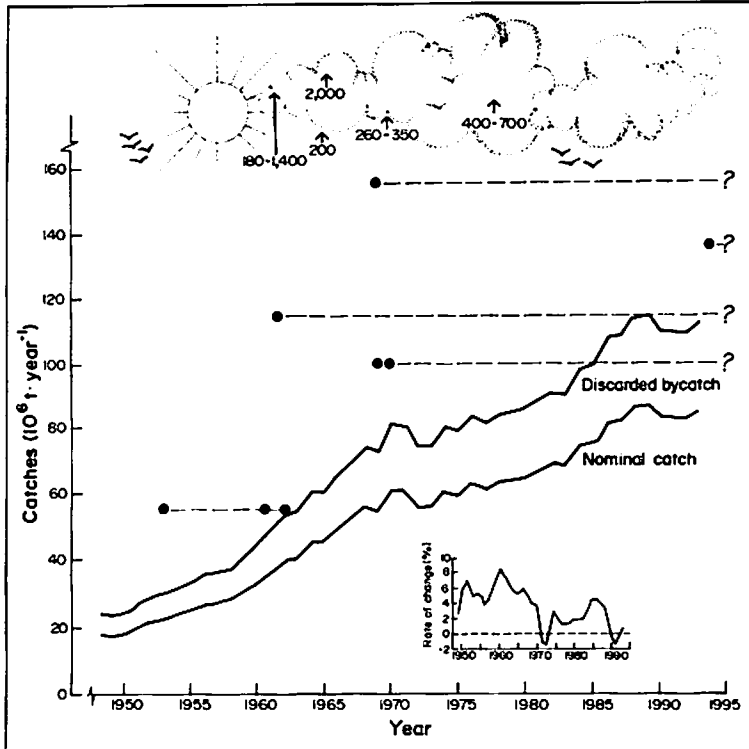

Fig. 1. Global marine catches, 1948-1993. To account for discarded bycatch, the estimate $27 \cdot 10^6 \text{ t year}^{-1}$ of Alverson et al. (1994) was applied to 1992, and prorated to the total catch of all other years. The full dots show some estimates of potential world catch, and the year they were published (from Table 1 in Pauly, in press). Note that none of these estimates explicitly considered the magnitude of the bycatch problem. The insert shows the % rate of change of the series, smoothed over three years (adapted from FAO Yearbooks).

Fisheries catches, which have grown in leaps and bounds since WWII or more precisely by around 4-8% per year in the 1950s and 1960s, have been stagnating since the late 1980s, even though 1993 (the last year for which global figures from the Food and Agriculture Organization of the United Nations are available) with catches and aquaculture production slightly in excess of 100 million tonnes, was the largest ever.

FAO has well documented the extent to which present fishing practices are unsustainable, emphasizing, e.g., that the overwhelming majority of the stocks it monitors are either overfished, or recovering from previous overfishing (Garcia and Newton, in press). Other global studies have estimated the discarded bycatch of fisheries, presently a staggering 27 million tonnes per year (Fig. 2), and the extent of economic losses experienced by the world fisheries — over US\$ 50 billion per year, largely met by subsidies.

No competent observer believes that this situation can last, and indeed, international efforts are now being made to radically change the ways of our fisheries, and to put them on an economically and biologically sustainable basis.

The second of these aims - and perhaps some of the first - will have to involve ecosystem consideration: the stocks the fisheries exploit are parts of ecosystems, most resource species feed on one another, and sustainable fisheries must account for this. Fisheries scientists have been reluctant to consider such ecosystem interactions in the past: it did not seem necessary, and it was dubious if it could be done anyway — especially if one has to invest several years' worth of one's time to construct and validate even a single-species simulation model (see Hertlein, this issue for a recent example).

This perception of the situation has changed: fisheries scientists, throughout the world now largely agree that they must find ways to account for species interactions - even when they still perform single-species assessments. Several generic approaches for multispecies analysis have therefore recently emerged. One of these is multispecies virtual population analysis (see below); another simpler approach is the construction of mass-balance, trophic models, developed by the authors on the basis of earlier work by J.J. Polovina and co-workers at the National Marine Fisheries Service laboratory, Honolulu, and presented as the ECOPATH II approach and software, in an earlier issue of *Naga* (Christensen and Pauly 1991).

We will briefly review major features of this approach, then move to the presentation of a new release of the software incorporating it, and whose features turn ECOPATH II (version 3.0) into an almost completely new approach (Box 1). We then present a recently initiated project through which we plan to construct a stratified database of trophic interactions, production, and abundance in the world oceans, based on 100+ ECOPATH II models constructed in collaboration with, and/or by colleagues worldwide.

The Modeling Approach and Some Key Results

The construction of an ECOPATH-type ecosystem model relies on the truism that, for any producer (e.g., a given fish stock) and time period (e.g., a year or season)

$$\begin{aligned} \text{Production} &= \text{fisheries catch} + \text{predation mortality} \\ &+ \text{other mortality} + \text{biomass accumulation} \\ &+ \text{loss to adjacent systems} \quad \dots 2) \end{aligned}$$

In addition, the groups in the system are linked through predators consuming prey. Such consumption can be described by

$$\begin{aligned} \text{Consumption} &= \text{Production} + \text{non-assimilated food} \\ &+ \text{respiration.} \quad \dots 3) \end{aligned}$$

This implication of the two relationships is that the model is mass-balanced, i.e., mass is "conserved", or accounted for. Call it as we may, this principle provides an extraordinary rigid framework — formalized using a system of linear equations — through which the biomasses of different consumer groups within an ecosystem can be estimated, along with the trophic fluxes among them (Fig. 2).

Important here is that the information required to complete an ECOPATH II model is of the very type routinely collected by fisheries scientists, (e.g., catches) or estimated in the context of single-

Box 1. Announcing the release of ECOPATH II Ver. 3.0.

ECOPATH II (Ver. 3.0) is now ready for release. The new version includes the following novelties, among others:

The Windows-platform: The 'old' ECOPATH II was programmed in Microsoft Professional Basic, and was (and still is) a versatile program with the major advantage that it can be run on basically any PC using DOS. The old version further has the advantage that it is very simple to use for newcomers, as there is a 'natural path' for the user to walk through the routines. In contrast the new version, programmed in Microsoft Visual Basic, and which has the flexibility (spreadsheet input forms, multiple open windows, etc.), and consequently also the complexity of Windows programs is much more powerful, but it also takes more effort on the user's part to use these facilities. We wish to offer the advantages of both the DOS and the Windows platform; thus we will continue to support the DOS version (2.2+) of ECOPATH II; the DOS and Windows versions can share data files.

The graphics: Up to now, ECOPATH II has had very limited graphing facilities, and it was up to the user to produce graphs for presentations. A major new improvement in the new version is an interactive method for construction of the flowchart, i.e., of the main output of ECOPATH II. Such flowcharts contain a wealth of information, and it is complicated and time-consuming to prepare them manually. It has not been easy to program the flowchart routine, however, due to the complexity associated with arranging up to 50 groups with connecting flows, labels, etc. Indeed this

complexity is the main reason why it has taken us two years to release the new version of ECOPATH II.

Another, simpler, but also very versatile, and information-rich new feature is the mixed trophic impact graph. This gives an overview of how each of the groups in the system impacts each other through both direct and indirect trophic interactions. A number of additional graphs are included (notably for comparing trophic "pyramids"), and more will follow in coming versions.

EcoWrite: In the new version it is possible to enter a remark for each input parameter at the press of a button. Such remarks may indicate the sources of estimates, describe how they were standardized, etc. Once the model is constructed, a reporting facility extracts the remarks, and opens a built-in word processor. The text may then be edited or saved in a form accessible from virtually any other Windows-based word processor.

Empire: Often system-specific estimates of input parameters are not available for all groups to be included in a model. In such cases it can be useful to use one of the many published empirical relationships (e.g., in Calder 1984), especially where there are physiological constraints likely to overrule local conditions, e.g., in the case of the consumption/biomass ratio of fish (see Pauly 1989). To facilitate parametrization, we describe a number of these relationships in a new, interactive routine ("Empire"). We intend to add relationships in each succeeding version, and we encourage readers to contact us if they know of relationships we should consider including.

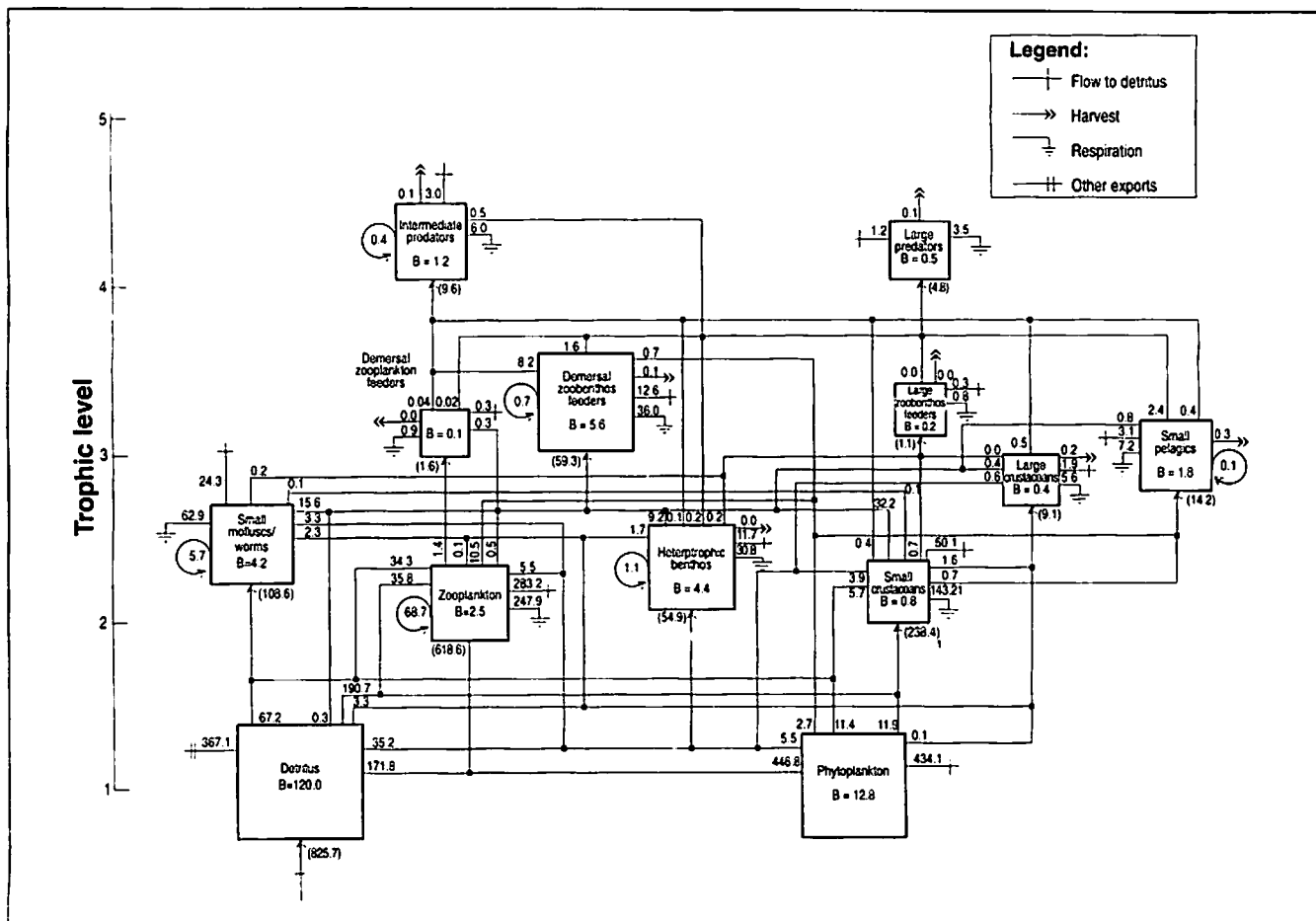

Fig. 2. Mass-balance model of the coastal fisheries resources of Brunei Darussalam, constructed using the ECOPATH II approach and software (from Silvestre et al. 1993).

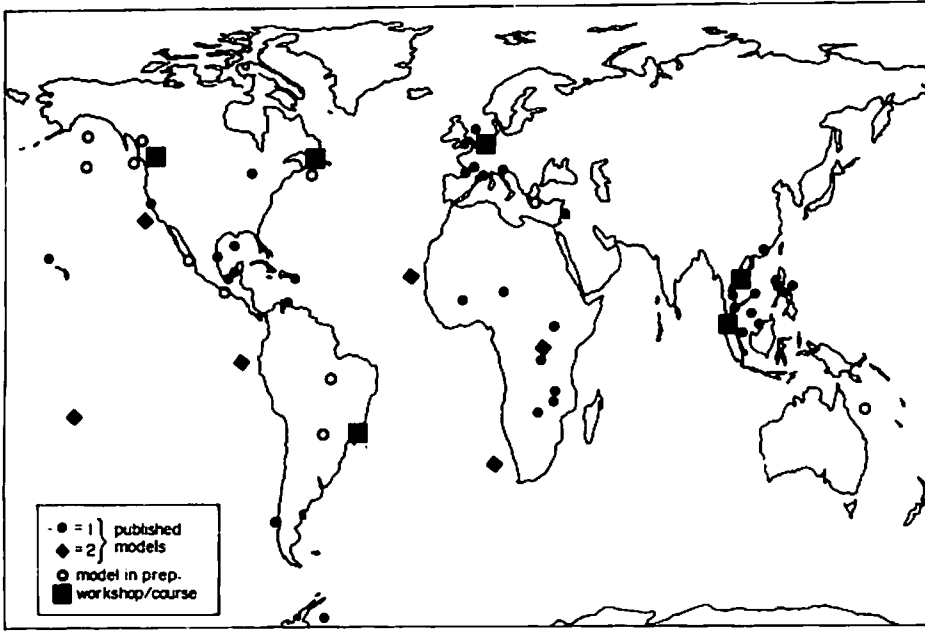

Fig. 3 World map showing locations of ECOPATH II models published so far (dots and diamonds) and of ECOPATH II workshops and training courses (squares).

species studies (biomasses, mortality rates, diet composition, etc.), along with biological information on the nonharvested components of the ecosystems — as usually studied by marine biologists.

Thus, at least these two disciplines are brought together every time an ECOPATH II model is constructed, and a large amount of scattered information is standardized, and rendered mutually compatible that would otherwise have languished in scattered journals, reports and filing cabinets. Box 2 presents a new approach through

Box 2. EcoRanger: a least square approach for construction of trophic models

Up to now, ECOPATH models have been constructed from a single set of input parameters representing means, or best guesses. The model-builder had to select an initial parameter set based on the available information, and iteratively change the set to derive a balanced model. The result would thus be only a *possible* model of the ecosystem in question.

In the new version, this is overcome through the "EcoRanger" module. This allows entry of a range — hence the name — and mean/mode values for all the basic parameters, i.e., for the biomasses, consumption rates, production rates, ecotrophic efficiencies, and all elements of the diet compositions. Random input variables are then drawn using user-selected frequency distributions (uniform, triangular, normal or lognormal) for each parameter type, and the resulting model is then evaluated (based on user-defined criteria, and physiological and mass balance constraints).

The process is repeated in a Monte-Carlo fashion, and of the model runs that pass the selection criteria, the best-fitting one is chosen using a least square criterion. This best model can then be used for further analysis and its characteristics can be studied. Notably, a global goodness-of-fit, R_E , is calculated along with parameter-specific indices (r_p) for each of the model inputs.

The EcoRanger module thus introduces a statistically based approach to fitting of ECOPATH II models, and most importantly it helps the user select the model that best fits a given set of constraints.

which this process has been made statistically more rigorous than previously.

So far, nearly 50 systems of marine and estuarine ecosystems have been published (see Box 3 for freshwater and terrestrial systems), authored by over 70 scientists (Fig. 3). Moreover, these models have not only summarized a large amount of data for the systems they represent, but jointly, they have allowed for powerful generalizations to emerge.

One of these is that the transfer efficiency of biomass between trophic levels in aquatic ecosystems, though highly variable, tends to have a mean value of 10%, as long suspected, but never before demonstrated conclusively (Fig. 4).

Another generalization is that the fraction of fish production consumed by other fishes, is even within strongly exploited systems, much larger than the catches, hence invalidating the guesses which led to Gulland's equation (see above, and Pauly, in press).

Yet another generalization is that the primary production required to sustain the world fisheries is far higher than previously anticipated, itself suggesting broad limits to the carrying capacity of the world's oceans (Box 4).

We consider these results, and other insights gained through the systematic application of the ECOPATH II approach to various ecosystems

Box 3. Modeling freshwater ecosystems (including ponds and farming systems) using ECOPATH II

The application of ECOPATH II to seven African lakes, four other lakes and two rivers - including two systems (Lake George and the River Thames), previously studied by the International Biological Programme — has amply demonstrated the applicability of ECOPATH II to freshwater bodies, whether tropical or temperate, exploited or not, and the comparability of the results obtained from this application with the results obtained from marine systems (see contributions in Christensen and Pauly 1994).

However, we will not be covering freshwaters in the global project described here: their surface area, relative to that of the ocean is minuscule (0.3%), while the data (fisheries catches, primary production estimates, etc.) required for the analyses are much harder to standardize. On the other hand, we welcome cooperation with colleagues interested in modeling freshwater bodies using ECOPATH II. Contact us for details.

That ECOPATH II also turned out to be suitable for description of culture systems was a pleasant surprise. The first batch of such applications was confined to ecosystems including at least some aquatic components, i.e., a southern Chinese silkworm - fish integrated system, a Philippine rice-cum-fish system, and a tilapia - elephant grass system among others. Another batch is emerging now from the work of J.P.T. Dalsgaard of ICLARM, who uses ECOPATH II to describe and compare the performance of farming systems, of which some may include fishponds, but many are entirely terrestrial (see p. 26, this issue).

The developments will demonstrate whether - as we believe - ECOPATH-type approaches may become in the next years a general tool, unifying fields as disparate as fisheries science, limnology, aquaculture, and farming systems research.

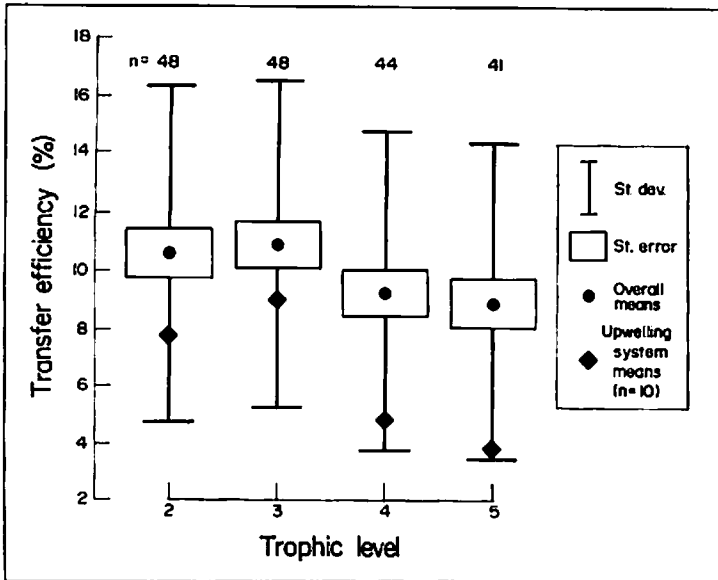

Fig. 4. Trophic transfer efficiency (TE, %) in 48 models of trophic flows in aquatic ecosystems by trophic level; based on the same sources as Fig. 2 in Pauly and Christensen (1995). Note the overall mean of about 10% (leading to conservative estimates of PPR), the absence of any trend with trophic level and the low means for upwelling systems, contradicting earlier assumptions (see Box 4).

Box 4. For a new start in aquatic food web studies

In a recent study we estimated how much primary production is required to sustain the global landings and discards of fish; this yielded a global estimate of 8% of total primary production, with a low value (2%) for the open oceans, while the estimates for shelf systems were as high as 25-35% (Pauly and Christensen 1995). The analysis was done by splitting the world catches into 39 species groups (i) for which fractional trophic levels (TL_i) were computed based on 48 published trophic models; average ecotrophic transfer efficiency between trophic levels (TE) was estimated to 10% based on estimates from the same models (Fig. 4), and the catches (C_i) were raised to Primary Production Required (PPR) using the relationship $PPR = catch^{TL-1}$.

Earlier, we had presented new approaches for rigorous estimation of trophic levels and their variance (Christensen and Pauly 1992), for calculating the aggregate flows into and out of each trophic level of a given ecosystem (Ulanowicz 1995), and thus to estimate TE values by trophic level and ecosystem type. This approach now permits the re-evaluation and the testing of alternative hypotheses concerning empirical relationships established earlier, and based on indirect, and often rather inaccurate methods of unknown precision.

For example, Ryther (1969), when estimating world fisheries potential guessed all the TE values he used, states "Slobodkin [1961] concludes that an ecological efficiency of about 10% is possible, and Schaeffer (sic) [1965] feels that the figure may be as high as 20 percent. Here, therefore, I assign efficiencies of 10, 15, and 20 percent, respectively, to the oceanic, the coastal, and the upwelling provinces, though it is quite possible that the actual values are considerably lower."

When we look back at those attempts, it is tempting to quote Parsons et al. (1979), who wrote in a now classic textbook with regard to similar relationships that "by definition, these relationships are advanced as being the most acceptable at the time of writing the text but it is to be expected that researchers will improve or disprove many of the processes discussed in the light of future scientific advancement. Such is the nature of science." And now is the time.

to amply justify our present effort to construct a global model of trophic interactions in the world ocean. The road we are taking can be briefly described as follows: we will use the existing stratification of the world oceans of Longhurst et al. (1995) to identify 50-60 large marine ecosystems (LMEs); within each of these we will make a detailed stratification based on water depth, and resource system type. Based on the systems to which they apply, published ECOPATH II models will be assigned to LMEs and substrata, and then raised to LMEs, oceans, resource system types, and to the world level.

For some groups ECOPATH II models do not provide sufficient constraints to limit the possible parameter ranges. This is particularly true for important consumers with low fishing and predation mortalities, such as marine mammal and mesopelagic fishes. For such groups, independent information is of special interest, and as an example we collaborate with marine mammal specialists at the Fisheries Centre, University of British Columbia, Canada, to evaluate the global trophic impact of marine mammals.

Required Steps and Expected Insights

For a global model to be more than the sum of its part, its components (i.e., the models representing LMEs) must have been derived independently of each other. Only then will overestimates in some models be compensated - at least in part - by underestimates in some other models.

Thus our emphasis on assisting collaborators in publishing *their* models, based on independent, locally available datasets rather than for us to attempt constructing all required models, based on widely available datasets and publications.

However, we do not perceive our collaborators as providers of local models, while we reserve ourselves the privilege of generating the global syntheses. Rather, all collaborators will be given sets of *all* ECOPATH II files generated by all other collaborators, so that they may generate their own syntheses of the data.

The completion of the world model will require as part of the interactions with interested colleagues and collaborators, a series of workshop, devoted to selected areas of high interest (see open dots in Fig. 3, and Box 5 for earlier workshops). One such workshop, sponsored by the UBC, and the Department of Fisheries and Ocean, Canada, will be held on 6-10 November 1995, in Vancouver, B.C., Canada, and devoted to the construction of models of inshore and offshore areas of the Northeastern Pacific. Another workshop, tentatively planned for late in 1996, will compare ecosystems along the West

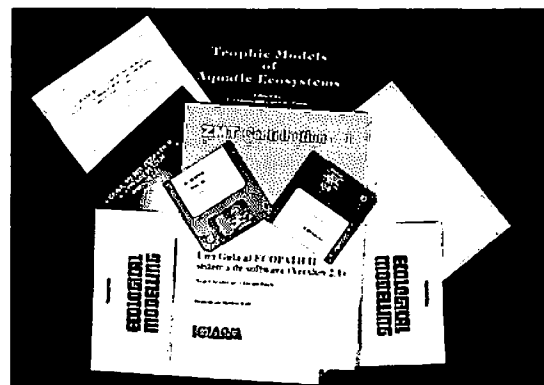

Fig. 5. Some products so far of the ECOPATH II project (see also Box 8).

Box 5. Using ECOPATH for training, education and research

Making an ECOPATH model is like taking a course in ecology. In the construction, main emphasis is on ecological relationships, not on the "modeling" *per se*. This feature has been made very clear by the courses and workshops conducted up to now — in Brazil, Canada, Germany, Malaysia, Mexico and Thailand.

At several universities, ECOPATH II is now being used as part of a curriculum, e.g., by letting students work with test datasets, or as teamwork where the students are assigned different parts of an ecosystem, then each group secures input parameters from fieldwork or the literature, while the final model construction is done *in plenum*. Construction of ECOPATH II models have also shown very useful for graduate studies, and to date more than a dozen MS and PhD theses have been completed using ECOPATH II as a structuring tool.

When constructing a model, information is needed of the trophic interactions of the entire ecosystem and this facilitates cooperation between, e.g., university researchers working on different ecological groups. As an example, production of prey must be sufficient to meet the requirements of the consumers. Therefore researchers who may perhaps otherwise remain focused on "their" groups of organisms must communicate, which may lead to cooperation, hypotheses testing, and other good things, such as publications presenting overviews of the important trophic flows in the system around a university field station.

ECOPATH models pertain to a certain time period. However, by producing new models year after year, for instance as part of regular coursework or surveys, the door is opened for analysis of time series of whole system properties — something that has been rarely done before.

Box 6. ECOPATH II and fisheries management

There is a link between constructing an ECOPATH model and doing management-oriented fisheries research. A precondition for managing the resources of an aquatic ecosystem is knowledge of these resources, e.g., what and how much is there? Further, the resource species impact on each other, predation usually being, by far, the single most important cause of mortality even in intensively exploited ecosystems. We thus need knowledge of trophic interactions, and the information in ECOPATH models is the basic information needed for the biological component of management.

We need more, however. We also want to know the likely consequences of changing fishing pressure, i.e., what will happen if the fishing effort for certain gears is decreased or increased? This cannot be done using ECOPATH models, even if the EcoRanger module (see Box 2) may indicate how changes in ecosystem structure might influence the fishery overall.

For fishery-induced changes on an ecosystem, another tool is needed: Virtual Population Analysis (VPA), which is widely used, though mostly in the Northeastern Atlantic. With this approach, the historic catches are used to "construct" the (virtual) population structure required to balance the catches. The approach can then be reversed to predict how changes in fishing pressure are likely to impact catches and population structure.

As it is of importance to answer "What if" questions using the VPA approach, one of us (V. Christensen) has worked over the last year on development of a robust version of multispecies virtual population analysis (MSVPA), taking biological interaction into consideration. This MSVPA builds on a method developed in the Northeast Atlantic area (see Sparre 1991) and has been documented elsewhere (Christensen 1995a); a test-version is available. It is planned to incorporate this into the ECOPATH II software, with which it shares many features. Release, however, will await publication of a number of test applications, and we therefore invite colleagues with interest in management of specific multispecies fisheries (preferably tropical) to notify us if they are interested in teaming up with us for this.

The data requirements are fishery catches for all important resource species in the study area, by month, and by length class, over at least an annual cycle. In addition some knowledge of biological interaction among the important fish species through stomach investigations is required. Please contact the first author for further information.

Coast of the Americas, from Alaska to Chile, and on to Antarctica. We welcome suggestions of additional workshops, including some that would be devoted to analyzing multispecies fisheries using Multispecies VPA (Box 6).

We expect these models and comparisons, and our planned work on globally important groups to lead to further generalizations, and also to regional integration of data — as did, e.g., our stratified models of the South China Sea (Pauly and Christensen 1993), now used to structure regional collaborative research by Southeast Asian research groups (UPMSI 1995).

Thus, when the global model emerges, we (including our partners) will be ready to incorporate into it all the insights gained at the local and regional levels, and we can use the global model for inferences on, e.g., human impact on the world ocean.

Box 7. Simulating changes

The Monte-Carlo routine built into the EcoRanger module of ECOPATH II (vers. 3.0) allows simulating the effect of ecosystem changes (including those induced by altered fishing patterns) on food web structure, a feature previously not thought amenable to study, at least not using the ECOPATH approach.

When simulating changes it is desirable to constrain the possible outcome(s), and to use optimization functions, commonly called goal functions (see Christensen 1994, 1995b), to select the most desirable outcome among the many possible.

In the new version of ECOPATH we have incorporated a number of such goal functions, ranging from E.P. Odum's "maturity" to Ulanowicz's "ascendency". The constraints provided by user-selected parameter act as filters, and EcoRanger then selects from among them the best fitting one, using least-square criteria.

If a model is originally balanced with a given set of parameters, and a change is forced onto a system, e.g., in form of biomass changes due to changed fishing pressure or other induced stress, the outcome of the analysis will be a new, predicted, model with the structure that is most likely to emerge under these constraints.

The new approach provides a bridge between traditional static models and simulation models in that it maintains the key characteristics of the static models, notably preservation of mass balance for all components, and a parametrization built on few and transparent assumptions; yet it provides predictions of how the system is likely to change. This also opens a new avenue for testing of goal functions when they are not used themselves as filter.

Box 8. How to obtain the ECOPATH II software and its documentation

The ECOPATH II software for construction of trophic ecosystem models can be obtained as ICLARM Software 6 in a new, Windows-based release (Version 3.0) in addition to the previous DOS Version 2.2.

For new users, two possibilities exist, either to order the software with a printed manual* for US\$20 (including airmail) from ICLARM's Information Division, or to enlist as collaborators of the ECOPATH II project, in which case we will send the software free of charge. Please contact us if you choose the latter option.

For registered users of ECOPATH II, we will supply on request the new version free of charge, with the manual in electronic form free of charge. The printed manual can be airmailed at cost (US\$15), while surface mailing is free.

The ECOPATH II software is copyrighted, but can be copied for free to colleagues and students as long as this is not done for commercial purposes. We encourage users to register (free of charge) as we can then keep them informed of newly discovered "bugs", new releases, major publications (see Fig. 5), etc.

*The manual for the Windows version (3.0) of ECOPATH II presently exists only in English, while the manuals for the DOS version are in English, French and Spanish. There is considerable overlap between the manuals for both versions, and we recommend the French or Spanish manuals to users of the Windows version who may be more fluent in these languages than in English.

Some of these studies will include:

- producing estimates of biomasses and trophic flows in the world oceans, and in different ecosystem types both globally and regionally; the latter will provide a background for regional studies in many small countries;
- evaluating the role of zooplankton, and of fish (notably the mesopelagics) in the global carbon cycle;
- producing estimates of how much primary production is required to sustain the global fisheries and the ecosystem components that compete with them and assessing their impact on sustainability, and thus getting a handle on the carrying capacity of the world oceans;
- estimating catch potential using different fishing patterns, e.g., harvesting top predators or fishing down the food web, and evaluating the impact of alternative management strategies.

We anticipate that numerous additional questions of global, regional or local interest will emerge, many as a result of our collaborators' work, and we look forward to the interactions that this implies. Box 8 describes how the ECOPATH II software and its documentation can be obtained, and we conclude this with an invitation to all interested to contact us, either through ICLARM in Manila, or at our other addresses, in Hirtshals and Vancouver, respectively.

References

- Allen, K.R. 1971. Relation between production and biomass. *J. Fish. Res. Board Can.* 28:1573-1581.
- Alverson, D.L. and W.T. Percyra. 1969. Demersal fish exploration in the Northeastern Pacific Ocean - an evaluation of exploratory fishing methods and analytical ap-

- proaches to stock size and yield forecast. *J. Fish. Res. Board Can.* 26:1185-2001.
- Alverson, D.L., M.H. Freeberg, S.A. Murawski and J.G. Pope. 1994. A global assessment of fisheries bycatch and discards. *FAO Fish. Tech. Pap.* 339, 233 p.
- Calder, W.A. III. 1984. Size, function and life history. *Harvard University Press, Cambridge.* 431 p.
- Christensen, V. 1994. On the behavior of some proposed goal functions for ecosystem development. *Ecol. Modelling* 75/76:37-49.
- Christensen, V. 1995a. A multispecies virtual population analysis incorporating information of size and age. *ICES Annual Science Conference. ICES C.M.* 1995/D:8.
- Christensen, V. 1995b. Ecosystem maturity - towards quantification. *Ecol. Modelling* 77:3-32.
- Christensen, V. and D. Pauly. 1991. The South China Sea: analyzing fisheries catch data in an ecosystem context. *Naga. ICLARM Q.* 14(4): 7-9.
- Christensen, V. and D. Pauly. 1992. ECOPATH II - a software for balancing steady-state ecosystem models and calculating network characteristics. *Ecol. Modelling* 61:169-185.
- Christensen, V. and D. Pauly, Editors. 1993. *Trophic models of aquatic ecosystems.* ICLARM Conf. Proc. 26, 390 p.
- Garcia, S. and C. Newton. Current situation, trends and prospects in world capture fisheries. *FAO Tech. Pap.* (In press)
- Graham, H.W. and R.L. Edwards. 1962. The world biomass of marine fishes, p. 3-8. *In* E. Heen and R. Kreuzer (eds.) *Fish in nutrition.* Fishing News (Books), London.
- Longhurst, A., S. Sathyendranath, T. Platt and C. Caverhill. 1995. An estimate of global primary production in the ocean from satellite radiometer data. *J. Plankt. Res.* 17(6):1245-1271.
- Parsons, T.R., M. Takahashi and B. Hargrave. 1979. *Biological oceanographic processes.* Pergamon Press, Oxford.
- Pauly, D. One hundred million tonnes of fish, and fisheries research. *Fish. Res.* (In press)
- Pauly, D. 1989. Food consumption by tropical and temperate marine fishes: some generalizations. *J. Fish Biol. (suppl. A):*11-20.
- Pauly, D. and V. Christensen. 1993. Stratified models of large marine ecosystems: a general approach and an application to the South China Sea, p. 148-174. *In* K. Sherman, L.M. Alexander and B.D. Gold (eds.) *Large marine ecosystems: stress, mitigation and sustainability.* AAAS Press, Washington, DC. 376 p.
- Pauly, D. and V. Christensen. 1995. Primary production required to sustain global fisheries. *Nature* 374:255-257.
- Ryther, J.H. 1969. Photosynthesis and fish production in the sea. *Science* 166:72-76.
- Schaefer, M.B. 1965. The potential harvest of the sea. *Trans. Amer. Fish. Soc.* 94:123-128.
- Silvestre, G., S. Selvanathan and A.H.M. Salleh. 1993. Preliminary trophic model of the coastal fishery resources of Brunei Darussalam, South China Sea, p. 300-306. *In* V. Christensen and D. Pauly (eds.) *Trophic models of aquatic ecosystems.* ICLARM Conf. Proc. 26, 390 p.
- Slobodkin, L.B. 1961. *Growth and regulation of animal populations.* Holt, Rinehart and Winston, New York. 184 p.
- Sparre, P. 1991. An introduction to multispecies virtual analysis. *In* N. Daan and M.P. Sissenwine (eds.) *Multispecies models relevant to management of living resources.* ICES Mar. Sci. Symp. 193:12-21.
- Ulanowicz, R.E. 1995. The part-whole relation in ecosystems, p. 549-560. *In* B.C. Patten and S.E. Jørgensen (eds.) *Complex ecology.* Prentice-Hall, Englewood Cliffs, New Jersey.
- UPMSI. 1995. The role of shelf-oceanic shoal reef interactions in maintaining the biodiversity and fisheries of the South China Sea: a basis for the rational management and protection of the south China Sea. A proposal resulting from the LOICZ Open Science Meeting, 24-27 April 1995, University of the Philippines Marine Science Institute, Quezon City, Philippines.

VILLY CHRISTENSEN is an ICLARM Senior Scientist and project leader for the ECOPATH II project, while **DANIEL PAULY** is Principal Science Adviser at ICLARM, and Professor at the Fisheries Centre, University of British Columbia, Canada. E-mail addresses are: v.christensen@cgnet.com or VC@dfu.min.dk, and d.pauly@cgnet.com or pauly@fisheries.com.