

SH
207
E3
#11
c.2

Artificial Reefs for Marine Habitat Enhancement in Southeast Asia

**Alan T. White
Chou Loke Ming
M.W.R.N. De Silva
Flordeliz Y. Guarin**

**Artificial Reefs
for Marine Habitat
Enhancement
in Southeast Asia**

Library



100013163

#63

**Artificial Reefs
for Marine Habitat Enhancement
in Southeast Asia**

**ALAN T. WHITE
CHOU LOKE MING
M.W.R.N. DE SILVA
FLORDELIZ Y. GUARIN**

1990



ICLARM



**Association of Southeast Asian Nations/
United States Coastal Resources Management Project
Education Series 7**

SH
207
E3
#11
c.2

**Artificial Reefs
for Marine Habitat Enhancement
in Southeast Asia**

APR 05 1991

ALAN T. WHITE
CHOU LOKE MING
M.W.R.N. DE SILVA
FLORDELIZ Y. GUARIN

1990

Published by the International Center for Living Aquatic
Resources Management on behalf of the Association of
Southeast Asian Nations/United States Coastal Resources
Management Project

Printed in Manila, Philippines.

White, A.T., L.M. Chou, M.W.R.N. De Silva and F.Y.
Guarin. 1990. Artificial reefs for marine habitat
enhancement in Southeast Asia. ICLARM Education
Series 11, 45 p. International Center for Living Aquatic
Resources Management, Philippines.

Cover (*Top to bottom*): Four artificial reef types: *a*, tire reef
(Philippines) (Photo by A.T. White); *b*, concrete cube
(Singapore); and *c*, old oil rig (Photo by M.W.R.N. De Silva)
and *d*, oil-well jacket (Brunei Darussalam).

Photos by L.M. Chou, unless otherwise noted.

ISSN 0116-5720
ISBN 971-1022-83-4

ICLARM Contribution No. 660

8817

Contents

Acknowledgements	vii
Foreword	ix
Introduction	
Artificial reefs in the marine environment	1
History of artificial reef structures	3
Coastal resources management problems	5
Rationale for use	6
Ecology of Natural and Artificial Reefs	
General productivity and diversity	7
Fish yields	9
Type of space and habitat created	11
Fish attraction versus actual production	13
Site Selection, Structures and Design	
What may be useful in Southeast Asia?	16
Fish aggregating devices	17
Artificial reefs on the bottom	18
Large structures	25
Shoreline structures	26
Socioeconomic Valuation	27
Management Systems	
Approaches	31
Community control	34

Contribution to Coastal Area Management	
Planning considerations	36
What is missing?	38
Glossary	41
References	42

Acknowledgements

The authors would like to thank various individuals in Southeast Asia and elsewhere without whose support this book would not have been written. Dr. Angel Alcala started experimenting with tire artificial reefs in 1977 in the Philippines and has stimulated many other such projects. Ramon Micalat, Evangeline Micalat and Dr. Fred Vande Vusse shared their ideas and experiences in their field experiments on artificial reefs. Drs. Daniel Pauly, James Bohnsack and Robert Moffitt gave detailed comments on the manuscript. Finally, thanks are due to the editorial staff at ICLARM: Marie Sol M. Sadorra, Romeo J. Santos, Rachel C. Josue and Rachel Atanacio.

Foreword

The coastal waters of Southeast Asian countries have some of the world's richest ecosystems characterized by extensive coral reefs and dense mangrove forests. Blessed with warm tropical climate and high rainfall, these waters are further enriched with nutrients from the land which enable them to support a wide diversity of marine life. Because economic benefits could be derived from them, these coastal zones teem with human settlements. Over 70% of the population in the region lives in coastal areas--areas where resources have been heavily exploited. This situation became apparent between the 1960s and 1970s when socioeconomic pressures increased. Large-scale destruction of the region's valuable resources has caused serious degradation of the environment, thus affecting the economic life of the coastal inhabitants. This lamentable situation is mainly the result of ineffective or poor management of the coastal resources.

Coastal resources are valuable assets that should be used on a sustainable basis. Unisectoral overuse of some resources has caused grave problems. Indiscriminate logging and mining in upland areas might have brought large economic benefits to companies undertaking these activities and, to a certain extent, increased government revenues, but could prove detrimental to lowland activities such as fisheries, aquaculture and coastal-tourism dependent industries. Similarly, unregulated fishing efforts and the use of destructive fishing methods, such as mechanized push-net and dynamiting, have seriously destroyed fish habitats and reduced fish stocks. Indiscriminate cutting of mangroves for aquaculture, fuel wood, timber and the like have brought temporary gains in fish production, fuel wood and timber supply but losses in nursery areas of commercially important species of fish and shrimp; it has also caused coastal erosion and land accretion.

The coastal zones of most nations in the Association of Southeast Asian Nations (ASEAN) are subjected to increasing population and economic pressures brought about by a variety of coastal activities, notably, fishing, coastal aquaculture, waste disposal, salt-making, tin mining, oil drilling, tanker traffic, rural construction and industrialization. This situation is aggravated by the expanding economic activities attempting to uplift the standard of living of coastal people, the majority of which live in poverty.

Some of those in ASEAN have formulated regulatory measures for their coastal resources management (CRM) such as the issuance of permits to fishing,

logging, mangrove harvesting, etc. However, most of these measures have not been effective due partly to enforcement failure and largely to lack of support for the communities concerned.

Experiences in CRM in developed nations suggest the need for an integrated, interdisciplinary and multisectoral approach in developing management plans that will provide a course of action usable for the daily management of the coastal areas.

The ASEAN/US CRMP arose from the existing CRM problems. Its goal is to increase existing capabilities within ASEAN for developing and implementing CRM strategies. The project, which is funded by the United States Agency for International Development (USAID) and executed by the International Center for Living Aquatic Resources Management (ICLARM) in cooperation with ASEAN institutions, attempts to attain its goals through these activities:

- analyzing, documenting and disseminating information on trends in coastal resources development;
- increasing awareness of the importance of CRM policies and identifying and, where possible, strengthening existing management capabilities;
- providing technical solutions to coastal resources use conflicts; and
- promoting institutional arrangements that bring multisectoral planning to coastal resources development.

One of the information activities of CRMP is to produce or to assist cooperating agencies in producing educational materials on coastal environments for general audiences. In the form of books, booklets or leaflets, these materials are primarily meant to create public awareness on the importance of rational exploitation of living coastal resources, environmental conservation and integrated CRM and planning.

Intended as a primer, *Artificial reefs for marine habitat enhancement in Southeast Asia* highlights the potential role of artificial reefs in CRM in the ASEAN region. It discusses the considerations necessary to maximize the effectiveness of artificial reefs as a means for fisheries management and habitat enhancement. It illustrates many practical examples of how artificial reefs have been used effectively and what are their limitations.

Chua Thia-Eng
Project Coordinator
ASEAN/US Coastal Resources Management Project

Introduction

Artificial Reefs in the Marine Environment

Artificial reefs are structures that serve as shelter and habitat, source of food, breeding area and shoreline protection. They are normally placed in areas with low productivity or where the habitat has been degraded.³⁴ They have been successful habitats for benthic organisms such as lobster, sea cucumber, oyster, abalone, topshell and seaweed, in addition to fish. They have also been used effectively in preventing trawling in specific areas.²¹ Their major functions are to:

1. concentrate organisms to allow for more efficient fishing;
2. protect small/juvenile organisms and nursery areas from destructive gears;
3. increase the natural productivity eventually by supplying new habitats for permanently attached or sessile organisms and by allowing the establishment of an associated food chain⁶⁰; and
4. create habitats and simulate natural reefs for desired target species.⁵⁶

Artificial reefs enhance marine systems. Enhancement occurs through the additional surface area and spaces created by structures in the water column. Additional surface area and space provide an opportunity for marine plants and animals to attach and seek shelter. The overall effect is to increase the amount of habitat available to marine life.

Coral reefs are one of the most productive marine ecosystems.⁶⁵ One of the main contributing factors to this productivity is the amount of surface area and textural variety provided by the reef for its tremendous variety of marine inhabitants. The more varied the surface area, space and texture of a coral reef, the more diverse and abundant are the marine organisms associated with them. There are other contributing factors, but it is this aspect of natural reefs which is analogous to artificial reefs and structures in the water. Artificial reefs attempt to mimic natural reefs.

A great variety of artificial reefs are deployed in marine areas to enhance the habitat or to attract fish. Old tires and cars, boats, barges, bamboo, concrete blocks, fiberglass, pipes and miscellaneous equipment have all been used for

artificial reefs in various parts of the world. Some new techniques for construction involve the use of waste products of coal combustion and mineral accretion⁶⁶, where calcium carbonates and magnesium hydroxides are precipitated from seawater onto conductive materials using direct electrical current.²⁸ Some materials such as cars have fallen into disuse because they release toxic chemicals from paint, plastic or other degradable materials.²⁰ In some countries, used tires are still preferred for artificial reefs while fabricated materials such as concrete have become more common.

Artificial reef designs have undergone steady modification with experience. The main considerations in choosing materials have often been availability, cost and ease of installation in the water, although adverse implications of certain materials or their effectiveness to enhance the habitat have often been overlooked. Debris, tires, and scrap materials have ended up along beaches due to inadequate fastening and anchoring methods. They have often damaged fishing nets and resulted in litter along beach resorts. Replacement of chain and ropes with more durable materials such as bands cut from car tires have added durability to tire modules and minimized such adverse impact.

The variation of artificial reef use among countries is significant. For example, about one-fifth of the coastline of Japan has some form of human-made reef. They range from several meters to 100 m deep in the water and from 100 m to 30 km from the shore. Reef blocks (usually of concrete) range from about 1 to 11 m in height and from 1 to 10 m in width. The weight ranges up to 70 tons in some cases. The different types of reef blocks number more than 100.⁵³

Almost any submerged object in an appropriate location can concentrate fish. The tendency for fish to be close to solid objects may account for the first appearance of fish on newly constructed artificial reefs.⁵⁹ Such structures also provide visual points of reference for fish in barren areas or as temporary shelter where fish can take cover to conserve their energy in currents.⁴⁴

Once attracted to an artificial structure, herbivorous fish may feed on algae that have colonized the surface of such a structure. Newly recruited juveniles serve as food for larger fish. Some fish may become permanent residents while others stay during certain life stages only.⁷

On a contrary note, one may ask, why place artificial reefs in the marine environment when they appear to be a form of pollution? In a broad sense, this is true because most things which humans add to the ocean are alien and are technically pollutants. All such structures or reefs have an impact on the marine ecosystem.²⁰ Though the intention in deploying different kinds of artificial structures is to enhance the environment to the benefit of people or the marine ecosystem, we should remember that there will always be detrimental and beneficial effects.

How effective are artificial structures in enhancing the habitat and productivity of a particular marine ecosystem? Do they really increase productivity or only attract fish and invertebrates from other areas?^{9,47,48,49} The question is not easily answered. Results cannot be generalized over many different kinds of artificial reefs in varied situations. This book attempts to provide some guidelines on how to design artificial reefs to maximize the desired results while minimizing adverse effects on the natural environment.

History of Artificial Reef Structures

Artificial reefs have been used to enhance coastal fisheries in Japan and in other countries for several hundred years¹⁶, but their widespread construction and application are recent, spanning the last 15 to 20 years. The concept of artificial reefs originated in Japan about the turn of the 18th century. Fishermen observed that fish catches were more productive in waters containing sunken ships. The catches declined as the wrecks disintegrated. In 1795, fishermen constructed large wooden frames and mounted them with bamboo and wooden sticks, weighted with sandbags, and sunk them in the sea at depths of about 36 m. They discovered that their catches around these structures were better than those around the shipwrecks. This prompted them to sink more such structures.³⁰ The use of designed reefs made from fabricated materials started more than 30 years ago.⁵⁶ The first generation of these designed reefs have since then undergone various modifications.

In the United States, an artificial reef was first constructed in South Carolina in 1860.²⁹ Before this, it was observed that fish could be caught in large numbers from inlets where trees had fallen and barnacles had grown. It was also discovered that fish numbers could be kept high in areas where stacked configurations of oak and pine logs had been sunk. The next artificial reef construction was by a boatmen's association in New York which used wooden tubs partially filled with concrete. Subsequently, more reefs using a variety of other materials such as old ships were constructed in coastal waters throughout the United States. The use of artificial reefs in freshwater habitats also occurred in the United States before 1930.

Widespread interest of Southeast Asian countries in artificial reef construction as a part of coastal zone management for resources enhancement developed only in the late 1970s (Fig. 1).

Thailand initiated an artificial reef construction program in 1978, covering seven coastal provinces along the Gulf of Thailand and the Andaman Sea. Thirty-four reefs set in areas 300 m² were constructed between 1978 and 1986. Reefs have also been constructed through private initiatives and funding

(fishermen's associations of Songkla, Chonburi and Petchaburi Provinces). Materials used have been old tires, open concrete tubes, steel pipes and wood.⁵⁰

In Malaysia, artificial reefs were established in the early 1970s where they started as initiatives of the small-scale fishermen in the east coast of Peninsular Malaysia, particularly in the states of Kelantan and Trengganu. Government-sponsored development of reefs was initiated by the Fisheries Research Institute at Penang in 1975 with the placement of reefs made of used tires. Since then, reef development has progressed steadily with the establishment of 6 reefs by 1980, 40 by 1986, using more than 60,000 tires. Presently, the government is launching a nationwide program for the construction and monitoring of artificial reefs under the Fifth Malaysian Plan (1986-1990). About 60 sites have been used for artificial reef placement in Peninsular Malaysia and 17 in Sabah and Sarawak. Ninety percent of the reefs are made of tires while the rest are of concrete culverts and scrap vessels.¹⁷

The Philippines started a national program in 1981 and has established 70 small-scale artificial reefs in different parts of the country. The program involves the Department of Agriculture (DA) in cooperation with other national government agencies, provincial and municipal governments, civic organizations, village councils, fishermen's associations, tire companies and nongovernmental organizations (NGOs).³⁴ The first artificial reef of about 120 tires was constructed by Silliman University in 1977. It has since been monitored for fish diversity, abundance, productivity and is used by divers.⁴ Between 1990 and 1994, the Fisheries Sector Program of the Philippines will deploy more than 50,000 tires for artificial reefs in major bays around the country.

In Singapore, the National University of Singapore initiated an artificial reef project on an experimental basis in 1989 under the ASEAN/US Coastal Resources Management Project (CRMP). This project is monitoring the impact of tire and hollow concrete block reefs on the environment and measuring the costs and returns attributed to the reefs over several years. The investigation will also determine the effectiveness of these structures in heavily sedimented waters.

In Brunei Darussalam, artificial reef construction began in about 1984 for fish aggregation and habitat enhancement. These tire reefs are being monitored for their effects on fishing. The country has also used two oil rig jackets as experimental artificial reefs.²¹

Taiwan has a national program to place artificial reefs to enhance commercial fisheries. Indonesia has experimented in Jakarta Bay where old *bejaks* or pedicabs, now banned by the city of Jakarta, have been dumped into the bay to attract fish.

Although the history of artificial reefs is quite long, it is only very recently that large-scale programs have been developed by national governments. The

relative abundance of used and waste materials has also reduced the cost involved and, to a large extent, made it possible to build artificial reefs in developing countries. In Japan, most artificial reef development has been with newly fabricated materials and such large investments might not be economically feasible in other Asian countries.

Coastal Resources Management Problems

In Southeast Asia, the coastal areas are densely populated and heavily exploited. About 60-70% of the total population of the region resides in coastal areas. Industry and business, in general, which occur near the sea, put stresses on the marine environment. One of the primary consequences is the heavy exploitation and the severe degradation of inshore coastal habitats.

Coral reefs are in various stages of destruction in many areas in the region.⁶³ Reefs are often physically damaged by the use of fishing methods such as blasting, muro-ami, shallow water gleaning, inshore trawling, dragging of various kinds of nets and dropping of fish traps. Chemical pollution, the use of poison in fishing and sediment runoff caused by deforestation and poor land management have taken their toll on coral reef areas. Ornamental and building materials (shells and corals) are also extracted from reefs to the detriment of their physical integrity. This situation has prompted much interest in management and protection of coral reefs and also experimentation with artificial reefs to rehabilitate disturbed habitats.

Overexploitation of inshore fisheries in Southeast Asia is also common in most areas.⁴⁵ Fishing effort through numerous traditional and sometimes destructive techniques is depleting inshore fish stocks at an alarming rate. One solution to the problem of overfishing is to create more habitats through artificial reefs and thus, produce more fish which might alleviate the overfishing problem. Of course, the problem is more complex than this and requires comprehensive solutions which do not simply exacerbate the overfishing problem. Artificial reefs must be part of programs to reduce fishing effort and manage resources if they are to have an overall positive effect.

Marine resources or coastal area management in Southeast Asia is now beginning to respond to the numerous problems in coastal areas. The focus of all development ends up in coastal waters in the form of some kind of pollution or physical impact. For instance, industrial discharges containing toxic chemicals or thermal effluents have resulted not only in massive fish kills but also in the elimination of ecologically and economically important fish species; these have disrupted biological communities and biotic associations as well. Yet, most countries, especially developing ones in this region, depend on fisheries

resources to feed their populations and to generate livelihood. The marine environment also provides opportunities for recreation, tourism, transportation, mineral extraction, among other benefits. Management is imperative and the means of implementing coastal productivity enhancement programs need to be explored.

Rationale for Use

Artificial structures in the marine environment are intended to enhance marine habitat and productivity. They may act as aggregation devices to existing scattered individuals and/or allow secondary biomass production through increased survival and growth of new individuals by providing new or additional habitat space. Artificial reefs have also been considered as a practical means of limiting trawling in nearshore areas where commercial trawling competes with small-scale fishermen. Sensitive areas such as spawning and nursery grounds have been protected by artificial reefs which serve as barriers.⁵⁶

In Japan, artificial reefs have been developed primarily to improve commercial fisheries and mariculture potential as contrasted to the United States where they are used mostly to enhance recreational fishing.¹⁸ In both cases, they improve and/or increase fishing areas.

Nations concerned with conservation and enhancement of marine resources are looking at artificial reefs as mechanisms to alleviate problems of resource availability, and as sources of food, employment, income and recreation. It is equally recognized that artificial reefs can not replace well-managed natural reef ecosystems but can only enhance degraded systems or provide for the extension of the productivity of natural reefs or emulate them in areas where reefs never existed.

Ecology of Natural and Artificial Reefs

General Productivity and Diversity

Many studies have compared artificial reefs to natural reefs in terms of community structure, density, biomass of fish and diversity of organisms. Natural reef communities in most studies have had lower density and biomass than artificial reefs in almost all cases.¹⁰ Most of the studies have also been conducted on temperate reefs where the reef complexity is naturally less than those in tropical waters.

Similar community structure and diversity is generally found on natural and artificial reefs depending on site-specific factors. Studies in tropical areas have generally found fewer species on artificial reefs as compared with natural coral reefs.^{23,1} For example, butterflyfishes monitored as an indicator of coral cover and general reef quality showed about one-half the diversity on an artificial reef in southern Philippines compared to an adjacent coralline area. It has been concluded by several observers that the ability of fish and invertebrates to use both artificial and natural reefs depended on the species.⁴⁶ Table 1 compares the characteristics of coral and artificial reefs.

Even though community composition may be similar, it is not uncommon to find more than twice the biomass and number of individual fish on an artificial reef compared to natural reefs. The exceptions seem to occur in tropical coral areas where some studies have found less biomass, abundance or fishing success on artificial reefs.¹⁰ Coral reefs have been shown to harbor larger individual fishes as compared with tire reefs, presumably because of space for hiding.³⁹ Yet most studies in temperate areas showing greater biomass and density of fishes on artificial reefs as compared with natural reefs suggest that artificial reefs are more complex and provide more cover than natural reefs.¹⁰ Artificial reef success is also related to position in the surrounding habitat.⁵¹ Table 2 compares standing crop and diversity of fish during prereef and postreef inventories conducted in Hawaii. Data showed an increase in the number of species and standing crop after deployment of reef materials.¹³

If artificial reefs provide a stable substrate, at least in shallow tropical areas, the reef may become eventually covered with living corals. The growth of 30 species covered about 15% of the surface area on a five-year-old tire reef in the

Table 1. Comparison of characteristics of coral and artificial reefs.²¹

Coral reefs	Artificial reefs
Natural living structures depend on specific environmental factors such as light, salinity, temperature and suitable substrate for basic framework development.	Artificial structures are independent of environmental conditions for basic framework development.
Shape, size, location and orientation depend on environment and age.	Shape, size, location and orientation do not depend on environment and age.
Basic framework of CaCO ₃ . Development is slow as coral growth is approximately 15-20 cm/yr at best. No cost involved.	Basic framework of metal, concrete, tires, wood, etc. Rate of framework development could be fast but cost-related except as natural growth occurs.
Longevity of basic framework is indefinite.	Longevity of basic framework depends on materials.
Recruitment of marine life is dependent on environmental conditions, shape, size and biological health of coral reef.	Recruitment of marine life is dependent on environmental conditions and the nature of framework.
High primary production from algae, corals, etc.	Primary production is dependent on area available for photosynthetic marine organisms to grow on basic framework.
Recesses and crevices naturally present in the framework provide shelter and hiding spaces for a large variety of marine organisms.	Hiding space provision is limited by the basic framework. The size and species attracted will depend largely on the size and nature of hiding spaces provided which depend on cost.
Establishment of new coral reefs through transplanting and other techniques is slow, time-consuming and of limited application.	Establishment of artificial reefs is relatively fast and has proven to be cost-effective in specific instances.
Fish production figures of 9.7-32 t/km ² /yr of coral have been recorded. ^{38,64}	Very little actual detailed work carried out on fish yield, etc. However, definite enhancement in fish aggregation has been recorded. In the Philippines, 312 m ² of bottom area of artificial reef has produced yields of 2 kg/week.

Philippines.²⁵ Most species grew at the same rate as on natural substrate. Observations on this same tire reef after ten years of growth noted that more than 40% of the surface area was covered with coral growth. Table 3 shows the growth of hard corals on the tires of an artificial reef near Dumaguete, Philippines.⁴

Table 2. Average number of species and standing crop of fish at various artificial reef sites in Hawaii prior and subsequent to the deployment of artificial reef materials. ¹³

Reef	Prereef inventories		Postreef inventories	
	No. of species	Standing crop (kg/ha)	No. of species	Standing crop (kg/ha)
Maunaloa Bay, Oahu	20	7	43	154
Waianae, Oahu	32	19	41	137
Kualoa, Oahu	24	17	No subsequent surveys	
Kaewakapu, Maui	6	0.6	25	41

Table 3. Growth of hard corals on the tires off Bantayan, Dumaguete, artificial reef constructed in May-June 1977. The corals were measured on 27-30 June 1980.⁴

Genus	No. in sample	Short diameter (cm)		Long diameter (cm)		Mean yearly growth in long diameter (cm)	Minimum-maximum yearly growth in area (cm ²) ^a
		Range	Mean ± SD	Range	Mean ± SD		
<i>Acropora</i>	14	2.4-9.6	5.8±2.1	2.8-11.6	7.0±2.3	2.33	0.50-8.04
<i>Dendrophyllia</i>	1	4.0	-	4.3	-	1.43	-
<i>Favia</i>	2	3.7-5.5	6.1	4.7-7.5	6.1	2.03	-
<i>Pocillopora damicornis</i>	11	2.1-11.5	8.8±4.6	2.2-18.3	8.8±4.6	2.95	0.38-11.52
<i>Pocillopora</i> spp.	17	2.0-20.7	11.0±7.2	2.1-23.7	11.0±7.2	3.67	0.35-37.39
<i>Seriatopora</i>	15	3.4-9.8	7.5±4.3	3.4-16.0	7.5±4.3	2.51	1.00-8.55
<i>Stylophora</i>	16	3.0-10.0	7.7±4.3	3.2-16.5	7.7±4.3	2.56	0.78-7.40
<i>Millepora</i>	2	4.5-4.7	6.1	4.7-7.5	6.1	2.03	-

^aBased on short diameter.

Fish Yields

Reef effectiveness whether for artificial or natural reefs is generally associated with fish abundance, diversity and fishing success. These measures tend to go hand in hand with only some variations according to particular species for fishing success. Because reefs attract fishermen, artificial reefs often receive greater fishing effort than surrounding areas and also show greater catches.¹⁰ Fish yields reported from artificial reefs vary considerably, depending on the methods used, fishing intensity, the surrounding habitat, among other variables. As on natural reefs, if the reef is overfished the catch will be less than the potential yield. Since artificial reefs tend to be small and concentrated, the yield per unit area may be high but the total catch is small or vulnerable to overfishing. Coral reefs undergo the same phenomena but usually cover more area than an artificial reef.

Natural and bottom artificial reefs support a well-defined fish community which is easy to overexploit because of low fish mobility, low natural mortality

and slow growth rates.¹⁰ In contrast, midwater or surface reefs or structures tend to concentrate mobile pelagic or shoaling species, making them easier to catch. Fish yields reported from these types of artificial reefs or Fish Aggregating Devices (FADs) tend to be high, relative to bottom artificial reef yields. Table 4 shows the production (in kg) for artificial reefs in several sites.

Table 4. Comparison of production (kg/m²/yr) from various artificial reefs.

Location	Production	Reef type	References
Philippines	1.2	tire	Alcala 1987
Philippines	10.7	bamboo module with <i>payao</i>	Miclat and Miclat 1989
Philippines	0.53	tire module with <i>payao</i>	Miclat and Miclat 1989
Italy (Adriatic Sea)	80-100 ^a	concrete block pyramids	Bombace 1980

^aHigh production of oysters and mussels.

Yields from small tire reefs, covering about 100 m² in the southern Philippines, through the use of bamboo traps showed about 1.2 kg/m²/year.² Compared to natural reefs in the vicinity with yields of about 30 t/km²/year or .03 kg/m²/year, the tire reefs produce a much higher yield but concentrated over a very small area. The total catch from this reef over six months was only 82.5 kg and more than 60% of which are shoaling or semipelagic species which are not reef residents. This result indicates that the reef temporarily aggregated fish more effectively than it served as a permanent resident habitat.

Eight bamboo reef modules combined with a floating FAD or *payao* with a bottom area of 254 m² at 12 m depth yielded 900 kg of fish in four months. The yield per unit area of this arrangement in the Philippines is very high while most of the fish caught were schooling and pelagic species attracted by the FAD.³⁴ Thirty-six tire modules, with an area of about 1,500 m² at 20 m depth, and five FAD structures recruited 41 commercially important species or about 50% of all the species recorded on the reefs. The catch from this area was 800 kg/year or about .53 kg/m²/year.³⁴

In Hokkaido, Japan, two fishing areas were compared to measure the effect of 40,766 m³ of artificial reefs in one area to 8,645 m³ of reefs in the other. It was estimated that 1,000 m³ of artificial reef volume increased octopus catches by 4% overall. While for flatfish, commonly caught around the artificial reefs, there was no evidence that the reefs increased fisheries production from the general area, even though they aggregated the fish at the reef sites.⁴⁹

In the mid-Adriatic Sea off the coast of Italy, a reef complex consisting of 12 concrete block pyramids was constructed to measure the potential for production

of mussels and oysters. The biomass of mussels per square meter was from 80 to 100 kg after four years of the complex's existence. This was considerably higher than that on natural substrates in the area.¹²

Type of Space and Habitat Created

Environmental factors and fish sensory abilities play an important part in attracting fish to artificial reefs. Current patterns; shadows; species interactions; visual cues of size, shape, color and light; sound; and touch and pressure affect the response of the fish to a structure.¹⁰ The effective range of attraction for surface and midwater fishes is up to 300 m.⁵⁷ For benthic species, the range is between 1 and 100 m, depending on the species.¹⁰ The zone around a reef may not be circular though, because fishes tend to congregate either upcurrent or downcurrent from the reef.²⁶ Most studies have shown that fishes are caught within 100 m of the artificial reef. However, on one reef in Japan, 240 m in diameter, 48% of permanent resident fishes were caught within 370 m from the center which might be explained by local current conditions.⁶⁷

The main considerations in creating a habitat are the area covered, vertical relief, complexity, surface, texture, spatial arrangements and orientation and location of the reef. Area and volume are probably mostly determined by the allowable cost so that examples vary from reefs of 100 m² or about 100 m³ in the Philippines to those with more than 2,000 m³ in Japan. In one experiment in Japan, production increased directly with reef size from 400 m³ to a maximum size of 4,000 m³(⁴³) and in other catches peaked at a volume of about 4,000 m³/km²(⁵³) (Fig. 2). Single reef units can be arranged into a reef complex. Reef complexes in Japan cover areas between 360,000 m² and 52,500,000 m².⁽¹⁰⁾

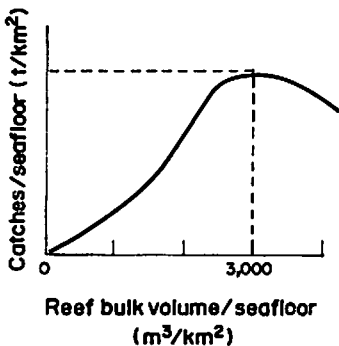

Fig. 2. Dependence of fish catches on reef density showing catches versus reef bulk volume per km² of sea bottom.⁵³

The importance of vertical relief of a reef varies with the environment and the type of fish being attracted and/or the habitat space being created. It is concluded that height is more important to migratory fishes than sedentary demersal fishes; and that horizontal spread is more important to demersal fish than vertical height. In addition, even though reef height is important, it is outweighed by total area and complexity.³⁶ Profile, another dimension, may be more important than actual height because vertical sides increase turbulent flow which produce sounds and create stagnation zones and lee waves that aggregate fish.²⁶

Complexity, another important factor in artificial reef success, includes design, spatial arrangement, number of chambers and openings and the amount of interstitial space.¹⁰ The number and size of fishes on artificial reefs have been correlated with the size and number of internal spaces.¹⁵ Internal chambers 2 m or more at the opening are too large for most fish. The best size range is between 0.15 and 1.5 m.²⁶ Most fishes will avoid enclosed chambers with only one opening and lobsters prefer shelters with more than one opening.^{58,26} Vertical panels which create shadows have been found to be more effective at attracting fishes than skeletal forms. Shadow-prone areas are preferred resting sites for some fishes.¹⁰

Texture of materials used to build a reef affects the ability of benthic organisms to attach. A varied texture--from rough to smooth--will allow a higher diversity of organisms to colonize the reef. Some invertebrates like corals will favor particular materials such as calcium carbonate for attachment. In all cases, the relative stability of the substrate is important, especially during storms when encrusting organisms may become detached from the surface.

Artificial reefs oriented perpendicular to prevailing currents and fish pathways optimize exposure to schooling and shoaling fishes. Japanese reef constructors generally leave a few meters between individual blocks, 50 to 150 m between sets, 300 to 500 m between groups and 3 km for reef complexes.²⁶ Spacing between reefs should consider the boundary of the enhanced fishing zone around individual reefs so that overlapping is avoided.³⁶

Location of artificial reefs is often said to be more important than all the other design considerations. Current, wave and storm exposure are very important factors that determine long-term success. Current turbulence, upwelling and/or downwelling are all positive factors for a reef, giving it more exposure to marine life. In contrast, waves and storms may be detrimental, especially to reefs at less than 20 m deep. Flat or gently sloping bottoms are considered favorable. The relation to physiographic features should also be considered.

Proximity of artificial reefs to natural reefs should be given due consideration as most observers agree that isolation is important.⁵⁴ For example, Japanese specialists recommend leaving 600 to 1,000 m between artificial and natural reefs to minimize fish interaction.²⁶ Depth affects the amount of light reaching a reef

and, thus, the rate of growth and colonization of numerous benthic organisms. So, everything else being equal, shallower depths are preferred within the limit of other factors such as surface disturbances of waves, boats, etc. In tropical areas, 15 to 25 m is considered a good depth range for the construction of artificial reefs.³⁴

Fish Attraction versus Actual Production

It is still unclear how effective artificial reefs are with respect to actual production of biomass or useful organisms as compared to their aggregating effect.³⁵ Polovina maintains that there is little evidence to suggest that artificial reefs substantially increase the standing stock of marine organisms.^{47,48} He says that despite the enormous volume of artificial reefs deployed off Japan's coast, there has not been any measurable increase in coastal fisheries landings. The only exception to this is the increase in octopus production attributed to reefs in Shimamaki, Japan.⁴⁹

Polovina⁴⁷ and Bohnsack⁹ also suggest that when growth or recruitment overfishing is occurring, artificial reefs are not a good solution. The reason is that for growth overfishing, artificial reefs simply aggregate young fish, making them more vulnerable to capture; and for recruitment overfishing, standing stock is reduced from unexploited levels so that habitat is not the limiting factor. They further point out that by aggregating adult fish, the reef simply increases catchability and hence fishing mortality, which reduces further the spawning biomass of fish.

To understand the perspective that artificial reefs only aggregate fish, we must look closer at the types of organisms, their behavior patterns, reef types and locations⁹ (Fig. 3). Is habitat a factor that limits the carrying capacity of shallow tropical marine waters? Since Southeast Asia is our model for which artificial reefs are attempting to emulate, the question is whether habitat is limiting in tropical reefs. To answer this, let us identify "tropical-reef associated organisms" and their needs and preferences. In this regard:

1. some (fish and invertebrates) are habitat- or shelter-limited such as groupers, eels and angelfishes;
2. many (fish and invertebrates) are obligatory reef-dwellers such as almost all tropical reef species;
3. many (fish) are territorial and not home-ranging such as groupers and triggerfishes;
4. many (fish) are demersal as contrasted to midwater or surface swimmers; and
5. most (invertebrates and algae) need hard substrate to adhere to.

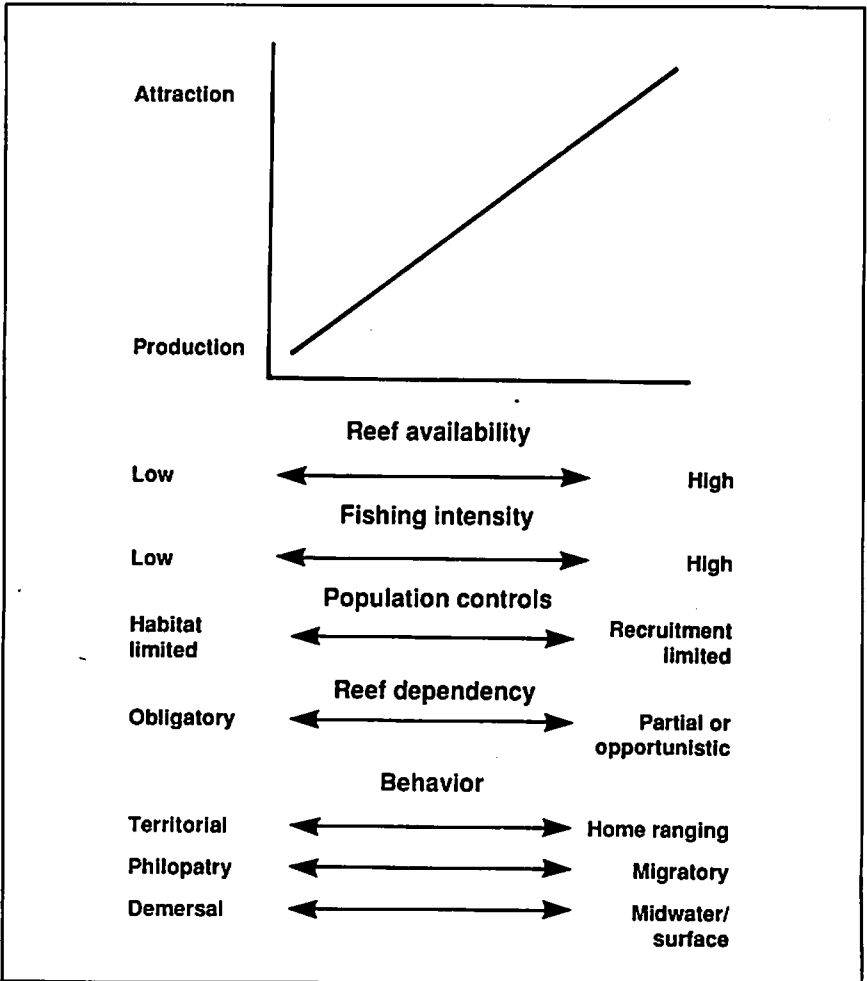

Fig. 3. Gradients predicted to be important for attraction or production of fishes at artificial reefs. Linear responses are shown only for illustration purposes.⁹

Thus, for bottom artificial reefs in shallow tropical areas, additional habitat space will at least increase primary production of algae and invertebrates and possibly extend the natural habitat to support a greater fish biomass. If habitat was not a limiting factor, then what role would tropical coral reefs perform in the first place? If this was the case, we could then assume that the removal of natural reefs would not reduce the carrying capacity of the nearshore areas for coral reef-associated fish and organisms. Since this is unlikely, we will continue to assume a degree of habitat limitation as a factor in tropical reef biomass

which is supported by the conclusions of Bohnsack.⁹ It is in these tropical sites that the increase of fish production by extending reef habitat is most likely to occur if other management considerations are attended to. Such considerations may include reef spacing and fishing intensity, which both affect the effectiveness of an artificial reef.⁹

In summary, a means of differentiating the aggregating and production attributes of an artificial reef, its sites and management requirements by identifying a set of gradients for any given situation, as done by Bohnsack. From Fig. 3, it can be seen that different environments, types of organisms and management approaches will fall in different places on the range of 'production' to 'attraction' for a particular reef.⁹ In general, artificial reefs may increase carrying capacity but do not necessarily increase standing stock in an exploited situation (Moffitt, pers. comm.). In this regard, attraction by itself is an acceptable function as long as there is a surplus population to harvest and as long as it does not lead to over-fishing (Bohnsack, pers. comm.).

Site Selection, Structures and Design

What may be Useful in Southeast Asia

The various types of artificial reefs are almost unlimited, if you consider most of these reefs have been constructed out of discarded materials. This is not to say that all such reefs are optimal or even useful. Some may actually detract from the marine environment and/or inhibit marine production because they release toxic chemicals. Some may also move and damage productive coral, seagrass or other habitats. When considering this problem and the factors discussed above which could affect the effectiveness of a reef, proper planning and design of artificial reefs is a must for a successful outcome.

Since this book focuses on the use of artificial reefs in Southeast Asia, we will limit our discussion to practical structures and design useful to this region. Although Japan has more experience than any other country with artificial reefs, many of its designs are not practical for the tropical coastlines of the developing countries of this region. Yet, some of the empirical findings of Japan are useful, transferable and worth considering. Nevertheless, we are mostly concerned with artificial reefs which are cost-effective for tropical waters with potential for coral reef growth and fishing by mostly small-scale coastal fishermen of the region. Whereas most countries are not willing to invest millions of dollars, Japan has approached the use of artificial reefs as a means of enhancing significantly the investment in an already highly capitalized fishing industry. Thus, sizeable investments have been rationalized as necessary to meet their goals.

Knowledge of fish behavior is useful in determining the type of structure to install. Basically, fishes attracted to artificial reefs may be classified as follows: (1) migratory surface and midwater; (2) migratory bottom; and (3) resident nonmigratory.³⁷ Fishes under the first category include the yellowtail, tuna, jack and true mackerel, sardine and dolphin fish and are usually found some distance from the fish attractors. Yellowtail and jack mackerel move from reef to reef. Migratory bottom fish attracted to bottom structures are breams, sea bass, fusiliers and some species of flatfish.³⁷ Category 3 examples are groupers, parrotfishes, eels, some snappers and surgeonfishes.

Fish Aggregating Devices

FADs are used to concentrate fish in offshore areas so that fishing effort is more efficiently utilized. They aggregate pelagic and schooling species common to deep waters and not associated with reef or shallow bottom areas. FADs were first used by native fishermen in the Pacific basin,⁴¹ and are known as *payao*. They consisted of a floating raft held in position by a weighted line, beneath which were suspended various materials such as palm fronds which serve as fish attractors. FADs are common today in Indonesia and the Philippines, where they are used by both commercial purse-seine and small-scale hook and line fishermen. The variety of designs is numerous and, in most cases, the materials are of local origin: bamboo, palm fronds, wood, tree branches, among others. The costly part of the FAD is the anchor and chain or rope which hold the device in place in currents or rough seas.

Fig. 4 shows one FAD (*payao*) design from the Philippines. This example is essentially a floating bamboo raft anchored by concrete weights. This *payao* was

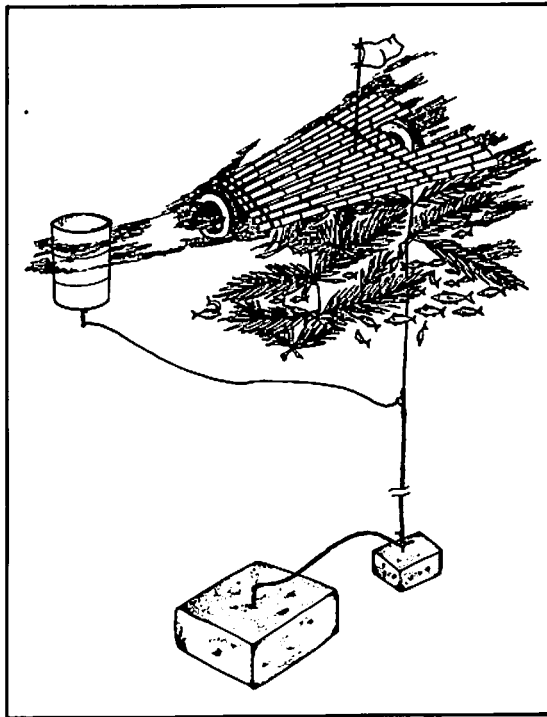

Fig. 4. The *payao*, a raft made of bamboo lashed together in a V-shape, is used to attract pelagic fishes.⁴⁰

placed 11 km off Mindoro Island in the South China Sea in an area about 2,000 m deep. The first harvest one month after its installation yielded 36.3 t and the second, a day later, yielded 3.6 t, both predominantly skipjack tuna.⁴⁰ The bamboo raft, palm fronds and weights were all minor expenses compared to the 16 mm nylon anchor line. The most important feature of the *payao* is a hanging line with coconut leaves tied to it. This weighted hanging line about 20 m long is the fish attractor.⁴⁰

The placement of a FAD is naturally contingent on the presence of pelagic fishes for attraction. Common targets are tuna, jacks and mackerel. Channels known to be migratory routes and prone to strong currents are favorite sites. Three-dimensional structures are more effective than two-dimensional ones. The number and species of fish attracted is related to the number of structures, distance offshore and water depth. Larger FAD structures attract more fish than small structures; and clear water is a positive factor.

FADs are clearly effective at aggregating fish and are becoming popular, often being supported by small-scale fishermen's organizations for implementation and maintenance. But as with all good things, there is a limit to the fish that can aggregate in any one area. Since they do not produce fish, limits must be imposed on the number of FADs to be placed in any one area and on fish yield for the target fishes to avoid overfishing.²⁴

Artificial Reefs on the Bottom

The most common objective for artificial reefs placed on the bottom is the enhancement of benthic habitat for fishes and/or selected invertebrates. Although these reefs also attract fish, they are installed to extend habitat and improve production. The ultimate goal in design is to replicate a coral reef habitat. Ideally, this may only be attained after a period of several years, with corals covering the reef. Some useful site-selection criteria for establishing artificial reefs in the Philippines by the Bureau of Fisheries and Aquatic Resources are:³⁴

1. over 1 km away from natural reefs;
2. near an alternative food source (i.e., seagrass beds);
3. constructed on a barren area of flat or gently sloping bottom of relatively good visibility; and
4. at depths of 15 to 25 m, protected from wave action but still accessible to local fishermen.

In Southeast Asia, the most common materials for artificial reefs are used tires, concrete, old boats, bamboo and occasionally, discarded land vehicles.

Plate 1. Tire artificial reef modules being lowered in Singapore waters.



Plate 2. Branching corals grow on a tire artificial reef, submerged for 12 years, off Dumaguete, Philippines. (Photo by A.T. White.)





Fig. 1. Southeast Asia and existing sites for artificial reef development in the region.

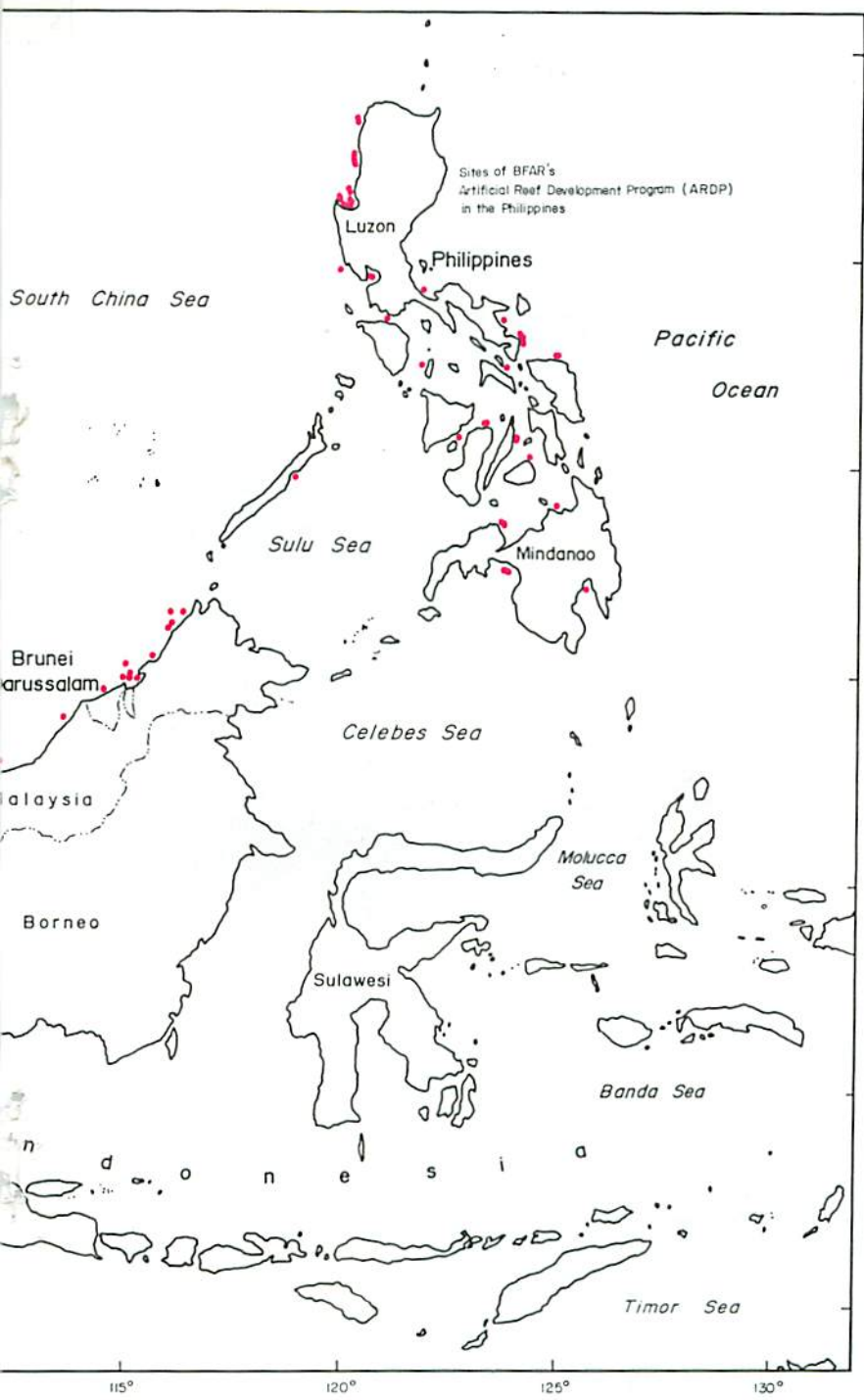



Plate 3. Concrete cube units in Singapore.

Plate 4. An oil-well tower, heavily encrusted with invertebrate organisms, serves as fish habitat and FAD in Brunei Darussalam.



Plate 5. An obsolete oil-well jacket being set into place in Brunei Darussalam. (Photo by M.W.R.N. De Silva.)

Table 5 shows the tradeoffs in cost, lifespan, handling and effectiveness at creating useful habitat. Of these, old tires are by far the most common material

Table 5. Comparison of materials used in artificial reef construction. (Modified from Edmund 1967.)

Material	Lifespan	Relative cost material	Shipping and handling	No. of crevices and surfaces
Old car bodies	3-5 years	low	high	high
Piles of rock	long	medium	high	very high
Building rubble	long	low	high	high
Concrete structures	long	high	high	very high
Old boats	medium	high	medium	high
Old tires	long	free	low	very high
Obsolete oil rigs	long	free	high	medium
Fiberglass	20 years	high	medium	high

used because of their availability at a low cost, their physical and chemical stability under water and their ease of handling. Tire modules comprising 36 tires or 9 pods of 4 tires each are a common configuration. The modules are tied together with corrosion-resistant rope or monofilament fishing line and placed in the water with about four concrete weights^{8,34} (Fig. 5). A number of modules can be placed in one area as shown in Fig. 6. They may also be combined with FADs on the surface (Fig. 6). A drawback of tires is their buoyancy which makes them vulnerable to wave action in shallow sites.

Concrete has had limited application in Southeast Asia because of cost. Various designs used in Japan are shown in Figs. 7, 8 and 9 and in Thailand in Fig. 10; a simple and cost-efficient design used in the Philippines is shown in Fig. 11. A concrete block complex of 12 pyramids made with 14 blocks each is shown in Fig. 12.

Old boats can easily be made into artificial reefs because all that has to be done is to sink them in appropriate locations. Yet the effectiveness of old boats is questionable, given the lack of control over the shape and design of the reef. Nevertheless, sunken boats are popular as scuba diving sites and are known to harbor fish. In this context, they may be most useful for recreation and as special attractions for divers. Such reefs could enhance bottom habitats and are cost-effective in certain areas.

Bamboo, as a material for reefs, is not very stable underwater since it deteriorates in three to five years. Nevertheless, because of cost-effectiveness and ease of handling, bamboo is a renewable source of artificial reef material. It has mostly been used in the Philippines. Fig. 13 shows a typical design which serves to provide structure and to attract fish through its high profile.

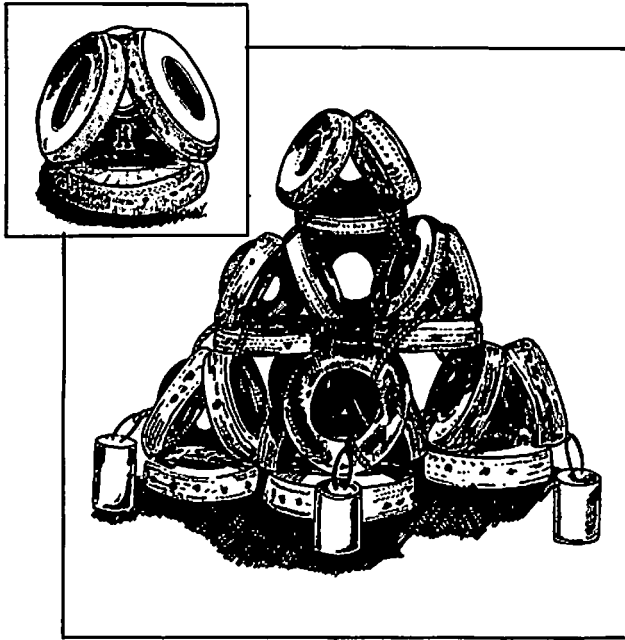

Fig. 5. Tire module of 36 tires anchored with four weights.³⁴

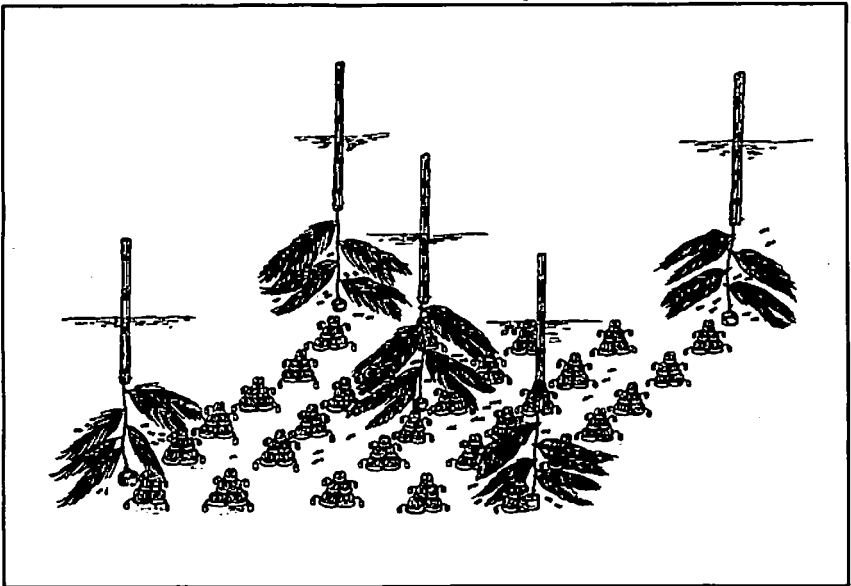

Fig. 6. Diagram of a 30-module tire artificial reef with five *payao* as the sites' marker buoys.³⁴

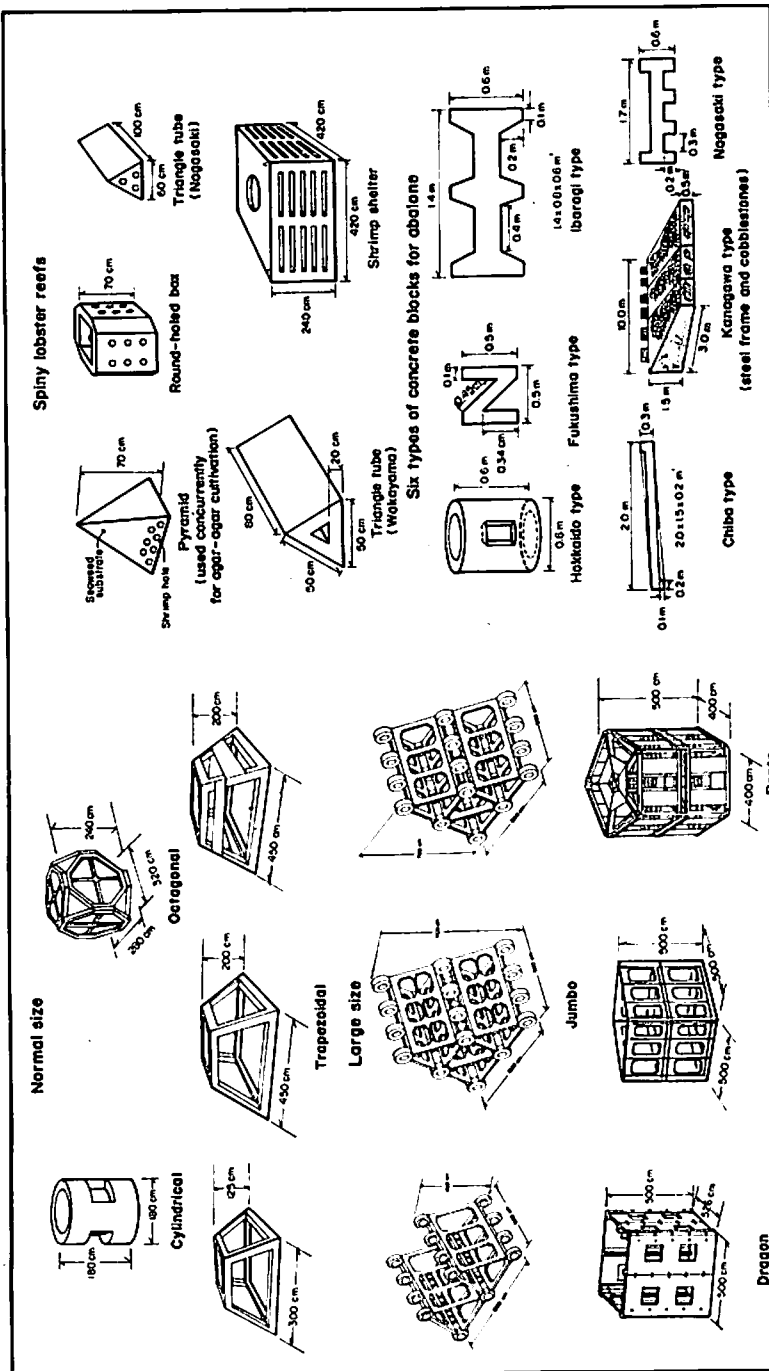

Fig. 7. Examples of normal and large reef concrete units in Japan. Some are designed for spring lobster and abalone. 60

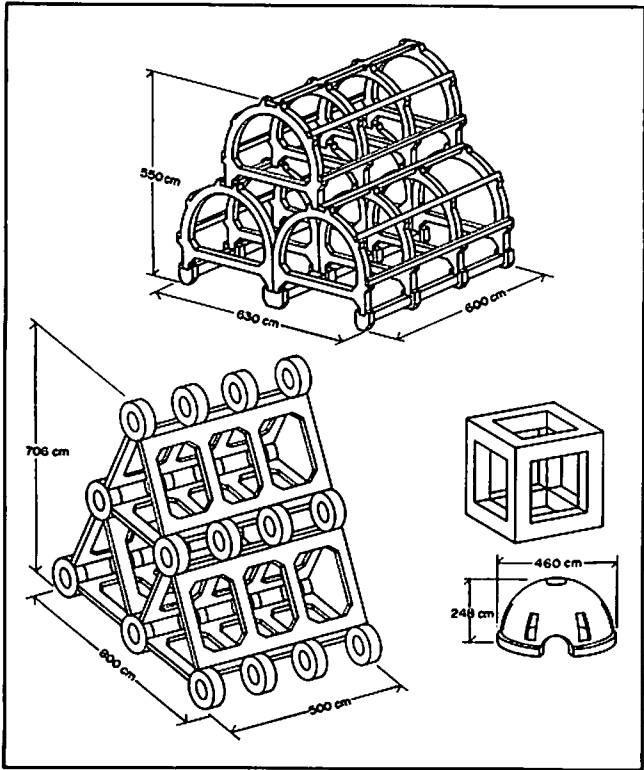

Fig. 8. Examples of Japanese chambered concrete modules used in constructing artificial reefs with large void spaces.^{13,37}

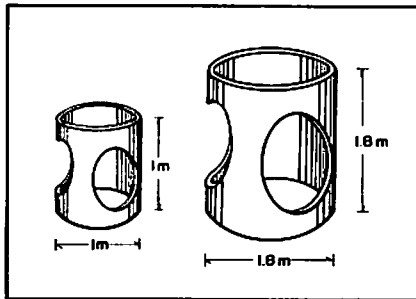

Fig. 9. Small and large reef units used off Hokkaido, Japan, to enhance habitat for octopus.⁴⁹

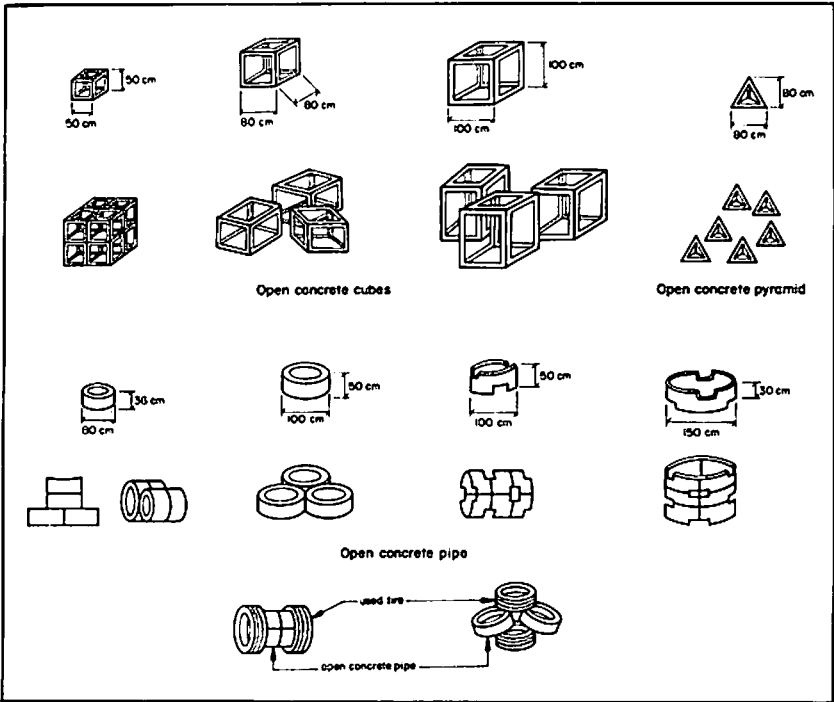

Fig. 10. Various modules of open concrete cubes, pipes and pyramids used in Thailand.⁵⁰

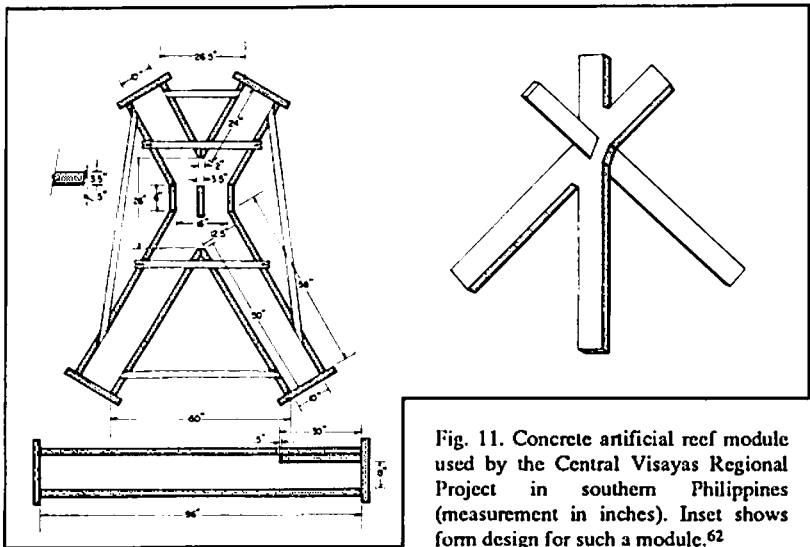

Fig. 11. Concrete artificial reef module used by the Central Visayas Regional Project in southern Philippines (measurement in inches). Inset shows form design for such a module.⁵²

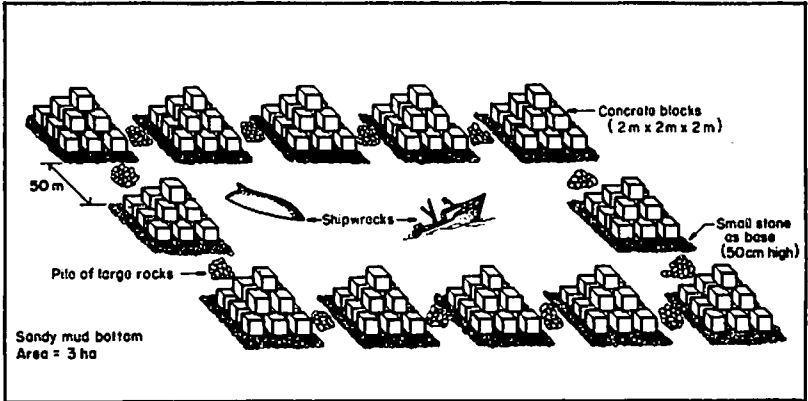

Fig. 12. Concrete block reef complex in the mid-Adriatic Sea, off the coast of Italy.¹²

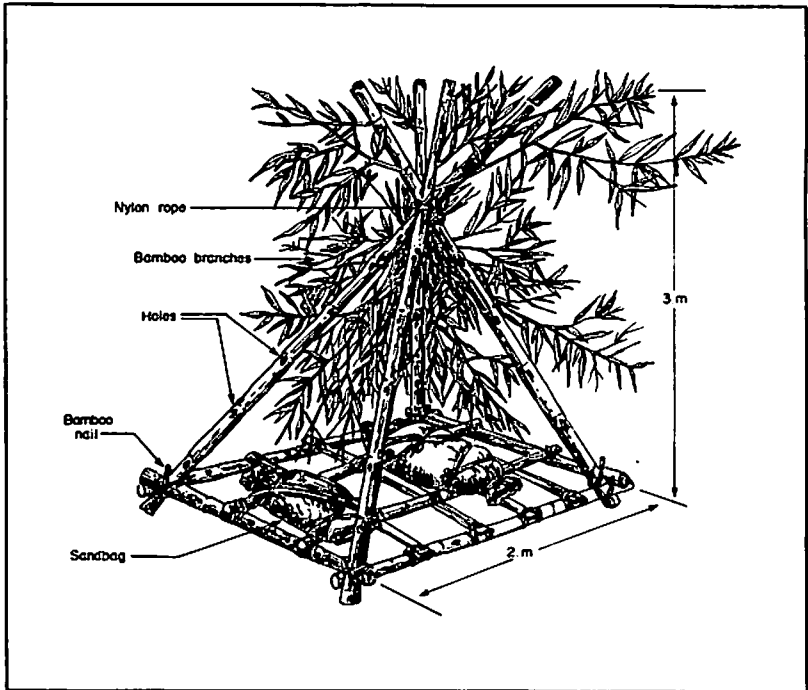

Fig. 13. A pyramid bamboo module used in the Philippines.³⁴

Large Structures

That oil rig towers aggregate fish can be confirmed by people who work on these platforms--they are rarely lacking in fish catch. Since these structures go from the bottom to the surface, they create a variety of microhabitats for different groups of fish and invertebrates.

One oil tower consisting of tubes and crossbraces 0.5 m to 1 m in diameter and rising 27 m from the bottom to the surface in Brunei Darussalam waters was surveyed in 1987. Its pipes and supports were heavily encrusted with invertebrates and algae, which formed a layer 10 cm or more thick. Barnacles were abundant but hard corals were absent except for one colony settled on a rope. Numerous colonies of soft corals covered the tubes while gorgonian fans occurred in the lower depths. Sea urchin and oyster were abundant. Coralline algae and filamentous algae were also abundant. The fish observed in an hour by an observer are shown in Table 6. Although not very diverse, the fish abundance and biomass were high for the small area occupied.¹⁹

Although not intended as artificial reefs and/or FADs, oil towers can serve both roles. At present, many oil towers are falling into disuse in Indonesia and Brunei Darussalam. Some of these towers could be used as artificial reefs if the government or oil company is willing to transport them to appropriate sites. Such expense could be large but it may be a beneficial use for outdated oil towers. Brunei Darussalam has done this on an experimental basis with two towers placed horizontally on the seabed at Two Fathom Rock in 1988. These towers provided an artificial reef with a volume of over 1,500 m³. They are being monitored for fish recruitment and yield.²¹

Table 6. Observed abundance of various fish taxa on offshore oil towers in Brunei Darussalam during a 60-minute dive by A. White in June 1987.¹⁹

Species	Abundance	Species	Abundance
<i>Apogon</i> spp.	5,000+	<i>Thalassoma lunare</i>	1,000+
<i>Cephalopholis argus</i>	10+	<i>Thalassoma trilobatom</i>	100+
<i>Epinephelus</i> sp.	1	<i>Cirrhilabrus</i>	500+
<i>Caesio cuning</i>	250+	<i>Pomacanthus annularis</i>	1
<i>Caesio</i> sp.	100+	<i>Heniochus acuminatus</i>	20+
<i>Pterocaesio tile</i>	500+	<i>Acanthurus dussumieri</i>	20+
<i>Pterocaesio diagramma</i>	1,000+	<i>Acanthurus mata</i>	10+
<i>Plectorynchus</i> sp.	2+	<i>Acanthurus</i> spp.	20+
<i>Carangoides</i> sp.	100+	<i>Ostraciid</i>	10+
<i>Caranx</i> sp.	500+	<i>Siganus virgatus</i>	30+
<i>Selar</i> sp.	500+	<i>Siganus lineatus</i>	10+
<i>Abudefduf sexfasciatus</i>	50+	<i>Platax</i> spp.	3+
<i>A. saxatilis</i>	50+	<i>Dasyatidae</i>	1
<i>Pomacentrus</i> spp.	5,000+		

In recent years in the United States, the primary objective of dumping decommissioned oil and gas platforms and scrap materials in the ocean is for solid waste disposal. It was estimated that aside from the benefits that would be derived from the artificial reefs, it would be more cost-effective to tow and dump these platforms than to salvage them.

The appropriate placement of wrecked ships can be a cost-effective means of constructing an artificial reef for the benefit of fishermen and recreational divers. Ships can provide habitats for numerous marine organisms. Some World War II shipwrecks are interesting places for scuba diving, especially if they have been encrusted with marine invertebrates and algae such as those in Truk Lagoon or Papua New Guinea.

Shoreline Structures

Jetties with pilings which extend into the sea are commonly associated with fishing with the use of hook and line. Recreational fishermen in many parts of the world frequent jetties to pass the time, fishing for pleasure or for food. The most effective type of jetty is one with pilings with varied spacing and diameters supporting the pier. Such a structure allows fish to swim between and around the pilings. Also the shade of the pier will attract fish which frequent rocky or protected areas such as groupers. Pilings are quickly colonized with encrusting organisms of various types, depending on the area and the surface texture.

Under new marine docks in southern Florida, artificial reefs were placed to add habitat to a stressed area. The reefs, made of large rocks, attracted numerous fish and macroinvertebrates which became associated with the habitat.³¹ This technique indicated that a simple artificial reef could mitigate the adverse effects of dock construction and contribute to improving the bottom habitat and the presence of fish in the area.³¹

All shoreline structures which extend into the water will have some reef and FAD effect. Those in deeper water and exposed to currents will naturally attract more fish than those very close to shore in shallow water with protected coastlines.

Socioeconomic Valuation

The most important qualification for an artificial reef is its economic viability and its contribution to the social well-being of the people concerned with its management and use. Few studies have adequately quantified the socioeconomic benefits derived from artificial reefs. Nevertheless, most communities and fishermen who use artificial reefs consider them an economic asset and are usually willing to contribute to their maintenance.

One study in 1973 found that an artificial reef off South Carolina was responsible for a 16% increase in the number of private boat anglers in the marine sport fishery and a 10% increase in the gross expenditures by private boat anglers.^{14,10} Although rigorous cost/benefit analysis has generally been lacking, there is a consensus that many artificial reef projects have warranted the expense. Yet, it might be wise to question this further with specific examples.

In Japan, records on the cost of large reef development show that for projects between 1976 and 1982, expenses averaged US\$45,000 for each of 2,200 reefs with volumes less than 2,500 m³; US\$545,000 for each of 352 larger reefs; and US\$2,150,000 for each of 107 enhanced fishing grounds which had total volumes averaging about 50,000 m³.⁽³⁶⁾ The average reef cost US\$21.36/m³ and produced a catch of 16 to 20 kg/m³ for average-sized reefs or a return of about US\$30/m³/year⁵³ (Fig. 14). These figures indicate that the reef construction cost is paid back in less than one year.

Some researchers, however, have implied that the economic and biological data justifying some of the Japanese projects were very insufficient.²⁶ Also, the effects of socioeconomic and industrial activity need to be investigated. One researcher recently noted that considering the enormous financial effort to develop coastal fisheries in Japan, it can be shown that the financial efficiency measured by cost/benefit analysis is negative.⁶⁰ Meanwhile, these projects sustained the activity of concrete producers and marine work companies, and prevented a serious decay of coastal fisheries.⁶⁰

It should always be kept in mind that if the primary source of catch is from migrating fish, then such high returns indicated in Japan are actually depriving other areas of fish catch. "Real economic gains occur only when artificial reefs enable capture of fishes that could not have been caught elsewhere for the same or less cost. Artificial reefs can be economic assets when fish are concentrated, resulting in less use of labor and fuel, and lower risk."¹⁰

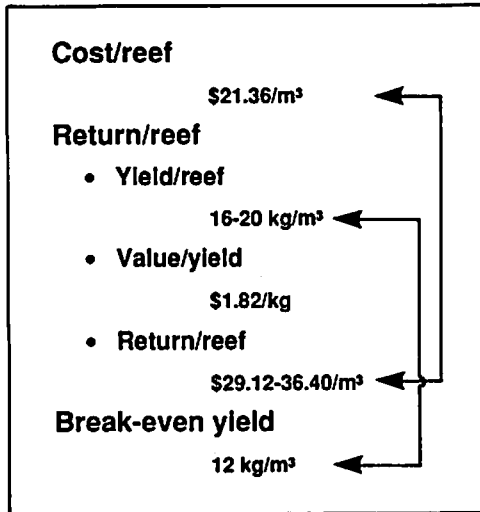

Fig. 14. Average costs and benefits from some artificial reefs in Japan.⁵³

For the Japanese example of Hokkaido, 33% of the respondents to a survey on the effectiveness of artificial reefs in the region thought they had expanded the fishing grounds while 38% thought they did not. Thirty percent could not decide. Twenty-six percent thought the reefs were very effective in increasing catches, 59% felt that they were fairly effective and 15% said they were not effective.⁴⁹ The response was mixed probably because of confusion over the increase of catch of a few species like octopus as compared with the fish aggregating effect for other species.⁴⁹

Other examples from the Philippines may help clarify this problem. One study of the fish catch from a bamboo reef with eight modules, combined with a floating FAD with a bottom area of 254 m², yielded 900 kg of fish over one year, valued at about US\$550. In contrast, the cost of the reef construction and maintenance was only about US\$100.³ Still, the question of attracted fish as compared with new habitat-dependent fish must be considered.

Economic analysis of FADs in open-access fisheries shows that it is unlikely that fishermen's aggregate profit will improve in the long-run unless there are restrictions on fishing effort and catch levels (Fig. 15).⁵² This is because overfishing will occur and the total fish yields will decline. Thus, total fish landings and employment in this fishing activity will decline. Management strategies are necessary to regulate effort. Of course, in the case of an underfished fishery where the small-scale fishermen target tuna, it may be difficult for overfishing

to occur as long as commercial-size fishing boats do not enter the fishery. Yet, experience suggests that the larger boats will monopolize the FADs²⁴ and the economic incentive of reduced cost and effort/catch will push the equilibrium toward an overfished stock.

Another tire reef covering 1,500 m² with five FAD structures conservatively produced about 800 kg/year catch with a value of US\$1,200.³³ The cost of construction and maintenance of this reef complex was US\$900 but the tires were given free.

The installation cost of 50 bamboo modules (65 m³) in the southern Philippines in a family-managed cluster is US\$260. In a four-year period, 26,000 modules (34,000 m³) were installed in 522 family-managed clusters. Within six months, a fish community developed which could be harvested from a standing stock of 1 kg/m³ on an average. Even though the effective module life was only four years, during this period, weekly harvest from two fish traps per cluster averaged 10 kg. This was sufficient to double the annual income of poor fishing families, after placement, operations and replacement costs have been deducted. The social benefit of this operation is that it demonstrates the relationship between habitat and reef fish populations, which stimulates community interest in restoring natural coral reefs.¹¹

The annual mussel production from a mid-Adriatic Sea reef complex of 36 concrete pyramids was from 200 to 250 t and for oysters, about 20 t. The revenue from the mussel sales alone paid for the cost of this reef construction over a three-year period. In addition, gastropods collected annually weighed up to 200 t and fish, 1 t. The concrete reef complex is acknowledged by coastal fishermen as a good area for set gear like hook and line, small nets and for diving. At the same time, trawling has been discouraged in the area since nets are caught in the pyramid structures.¹²

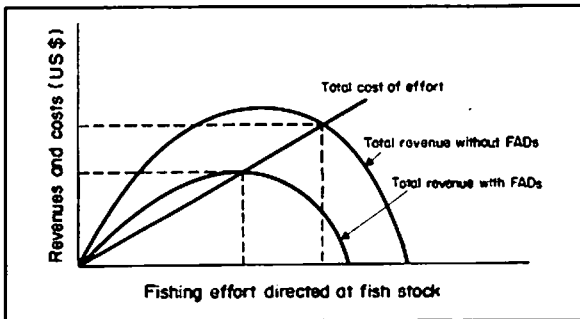

Fig. 15. Effect of FAD deployment on aggregate profits and total sustainable revenue in an open access fishery.⁵²

Recreational fishing has commonly been the impetus to install artificial reefs in the United States. In one case, the Boatmen's Association of Great South Bay, New York, built artificial reefs nearer shore in 1916 as their boats did not have the speed to take fishermen to offshore fishing sites. These reefs provided almost 30 years of productive fishing before they were rebuilt. Records before and after the rebuilding showed that the sea bass catch from the rebuilt reefs increased 25 times. Whether or not these reefs actually provided habitat for the breeding of sea bass can not be determined; nevertheless, the reefs provided years of social benefits to the fishermen.⁵⁹

To adequately value the socioeconomic benefits derived from an artificial reef project, the costs and benefits should be considered.²⁷

Costs:

1. site surveys (ecological, social and economic) and impact production study;
2. construction--design, materials; labor and transportation;
3. extraction--transportation, gear, labor and boat;
4. permit or licensing;
5. management--monitoring, repair and replacement; and
6. liability and insurance.

Benefits:

1. fish and invertebrates extracted;
2. social and economic well-being of fishermen users;
3. allocation of resources to desired groups;
4. enrichment of habitat/ecosystem for long-term production;
5. savings on fuel and fishing effort; and
6. revenues from recreation and tourism.

In short, the costs must be weighed against the benefits so that the net return is known. Based on local or international experience and costs for various types and sizes of reefs and/or FADs, costs can now be calculated. These costs will obviously reflect national labor wages, material availability and design preferences. Equally, the fish yields and other benefits derived can be estimated from previous experience and then quantified. The unknown factor alluded to previously is the extent an artificial reef simply attracts fish from other areas and/or decreases fish catch somewhere else. To the extent that fish attraction predominates, the fish harvest can not be considered purely a benefit. This question can only be answered on a site-specific basis when designing and then monitoring a project.

Management Systems

Approaches

Policymakers should consider the overriding goals and what can realistically be achieved in programs which develop artificial structures in the marine environment. Most countries in Southeast Asia have similar aspirations for the development of artificial reefs and FADs in their waters. Here are the commonly expressed outcomes:

1. increased fishery productivity in specific areas with attainable targets;
2. enhanced benthic habitat for fish, macroinvertebrates and algae;
3. increased fishing opportunities for coastal communities;
4. decreased fishing pressure on natural fishing grounds;
5. aggregated fish in openwater areas; thus, increased fishing effort efficiency and catch rates;
6. enlightened fishing groups and/or disuse of fishing methods in the site or shoreward of the artificial reef; and
7. increased coastal communities' participation in managing their fisheries resources through the construction of artificial reefs.

Achieving such goals requires resolving many conflicts of resources use. Ecological surveys should be made in the area of reef development to determine the probability of success. Planning through site surveys should be done in close collaboration with fishermen, administrators and researchers. In most cases, this does not happen because only one agency is responsible and it ignores the other participants in the long-term management necessary to ensure success. Several ongoing national programs are presented below.

The Philippines is installing many tire and bamboo artificial reefs in different regions; it is supervised by the Department of Agriculture. The program aims to provide supplementary or alternative fishing grounds for small-scale fishermen. It focuses on areas where natural coral reefs have been destroyed or do not exist.³⁴ The artificial reef program also serves as a means for disseminating information on resources management and conservation. Community-based management is the theme and the coastal residents are told to be directly involved to reverse the decline of fisheries resources. Fishermen are encouraged to construct and install artificial reefs. They thus become responsible for the repair, monitoring and management of the reefs.

Although artificial reef development in the Philippines has been moving along specific lines, there is no national policy to guide such projects. Here are some issues that have arisen in recent years:³⁴

1. Most people and policymakers think that artificial reefs are constructed only for fishing. No distinction has been made between artificial reefs for fish catch improvement and those for habitat rehabilitation. Consequently, almost all artificial reefs are fished without control or distinction as to their purpose.
2. Some artificial reefs are being destroyed by destructive fishing methods.
3. Some organizations want to own artificial reefs because they think that an artificial reef is a type of fishing gear. They do not understand that it is an extension of the natural resource base, hence, a communal property.
4. The responsibility of management is often unclear to the fishermen, municipal government and/or the national agency. Linkages are not well-established.
5. Sometimes there are conflicts in siting an artificial reef in relation to other fisheries activities.
6. Fishermen need good information to prevent misuse of the reef and conflicts of interest among user groups.
7. Technical knowledge is necessary for proper construction so that the reef will be stable and placed correctly, with the participation of coastal residents.

In Thailand, the national program for artificial reef development is intended to provide fishing ground for small-scale fishermen and to inhibit the operation of demersal trawlers in the nearshore waters. Three types of reef complexes (Fig. 16) were initially developed for placement near small fishing villages. Type 1 was placed in a long row to obstruct all mobile nets. The area was intended for hook and line and trap fishing only. Type 2 was placed for obstruction of trawlers and push-nets. Type 3 was arranged to provide nursery grounds for juvenile fish and fishing area for small-scale fishermen. The reefs in the initial project area of Rayong have been fished, as proposed, by hook and line, traps and with gill net or trammel net occasionally set adjacent to or over the reefs. The fishermen claim that they have benefited from the reef and have asked for expansion.⁵⁰

Thailand has continually expanded the program since 1980 with goals almost identical to those above. A theme has been to resolve the conflict between the small-scale fishermen and the trawlers who continue to fish in nearshore areas. The artificial reef program has helped to resolve this conflict. The workplan for

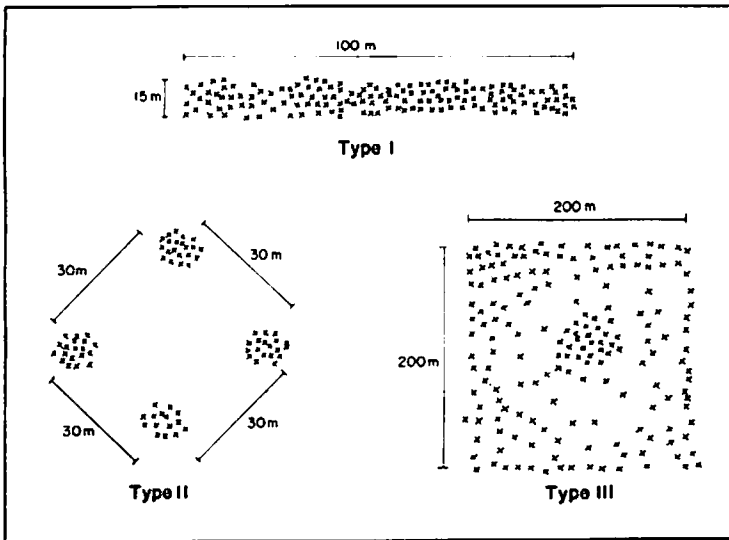

Fig. 16. Three arrangements of artificial reefs used in Thailand for distinct purposes.⁵⁰

reef construction follows a set sequence and is implemented by the Department of Fisheries. Here's the sequence:

1. Survey the site for contour, substrate, water visibility and other ecological conditions.
2. Determine the status of the marine resources, fisheries and use patterns in the area.
3. Evaluate the fishing communities in terms of income, fishing grounds and interest in the project.
4. To avoid conflicts of use, discuss reef locations with fishing village organizations.
5. Get permission from the Harbour Department and the Royal Thai Navy to place the reefs.
6. Inform fishing communities about the reef sites and the potential benefits if they participate in the project.
7. Construct the reefs with the assistance of fishermen, if possible.
8. Seed the reef site with nonmigratory and target species such as grouper and sea catfish.
9. Monitor and evaluate the reefs.

The Thailand approach to artificial reef development is more methodical than that of the Philippines. It also uses concrete blocks or cubes in most of the reefs as compared to tires and bamboo in the Philippines. Yet, there is more community participation in the Philippines and less involvement of the national agencies than in Thailand where the Department of Fisheries takes full control.

Fewer conflicts of interest arise because there is a coordinating body from outside the community which tries to anticipate conflicts of use.

A large concrete block complex of artificial reefs was constructed in the mid-Adriatic Sea to enhance the production of mollusks. In this situation, where reefs are rare and naturally very productive, the artificial structure has attracted several user groups. Commercial and sports fishermen, tourists and fishermen cooperatives have been attracted to the area for diving and fishing.¹² The lack of monitoring and the open access nature of the resource have encouraged indiscriminate exploitation of the site. The lack of national policy of use of openwater resources such as this has exacerbated the problem. This example highlights the need for zonation of a large site for different users and/or to allow only a limited access to particular user groups. Although contrary to open access regimes, it may be necessary to designate such reef areas for use by selected groups.

In Japan, artificial reefs are used to enhance the marine environment for fisheries and mariculture, which both rank high in the economy. In 1977, Japan had plans to place artificial reefs along 20% of its coastline.³² It has now accomplished them. Both shallow-water reefs (for shellfish and seaweed growth) and deeper-water reefs (for finfish) are used.⁵⁵ Various materials in different configurations have been used effectively to increase the productivity of a habitat. Increases in stocks of seaweed, sea urchin, crayfish and gastropods such as abalone and turbo shells⁴² and sea cucumber⁶ have been reported. Artificial reefs for fish were seen to make possible the creation of new fishing grounds from areas which were unproductive and low in fish populations. In the first six-year plan of the "Coastal Fisheries Consolidation and Development Program Act" (1976), about US\$250 million was allocated for artificial reef projects. This was doubled in the second six-year plan (1982) which highlighted the strong government commitment to fisheries development using artificial reefs.

Although the Japanese programs are impressive, they lack a proper cost/benefit analysis to show where the real benefits have accrued and at what costs they have been incurred. It is also disturbing that 20% of the coastline of Japan has artificial structures under the water. The ecological implications of such a massive effort can not be known beforehand and should be considered in such large projects.

Community Control

The Philippine national program in artificial reef development is partly based on the concept of community involvement. In addition, the Central Visayas Regional Project, in its effort to address the problem of coastal fish habitat

destruction, is using the strategy of artificial reef construction by fishermen. The involvement of fishermen in the development of bamboo reefs managed by families has had the effect of educating people about habitat management. It has discouraged destructive fishing, once rampant in the area, and opened opportunities for the farming of a variety of coral reef species. Management by family has given responsibility back to individuals and small groups for maintenance of the artificial and, in turn, natural reef areas.

To implement the community-based model, these key management elements are needed:^{64,11}

1. recognizing fishermen as the actual resource managers while realizing that total fishing effort must be limited;
2. community development workers willing to live and work in fishing communities;
3. an ongoing education program for and with the community;
4. involvement of local and government agencies to help coordinate technical support for community efforts;
5. formation of core management groups in each community;
6. simple, low-cost technologies which are profitable to the participants in a short period of time, equitable to the majority of fishermen and sound from a resources management perspective; and
7. a flexible regulatory framework allowing communities to make equitable resources allocation decisions.

The last element is lacking in almost all countries. It is only in the context of community-based projects in the Philippines where it is true. Here, even though there are no specific guidelines in national law to allow community control of marine resources, the Philippine Constitution allows local communities to take responsibility for their welfare and resources. Thus, such community projects have flourished in recent years to the benefit of those involved and the marine environment.

Community control of low investment type of artificial reefs has a place in developing countries, where it is necessary to involve coastal fishermen and to show quick results. These benefits can be expected from such projects:¹¹

1. Fast and significant benefits to fishermen. This gives the project credibility and helps maintain the fishermen's enthusiasm for managing the reefs.
2. Fishermen can understand the relation of habitat to reef fish. This learning can be transferred to coral reef management and provides an incentive to prevent destructive fishing in their area.
3. The coastal residents begin to realize that they can have a positive influence in managing their marine resources for their own economic and social benefits.

Contribution to Coastal Area Management

We are now at a time in the history of marine resources management when it is clear to most people that fisheries resources are finite. The oceans can only produce a limited quantity of fish and other useful organisms. Overfishing is occurring and, in many areas, habitats have been disturbed or destroyed. We thus have to maintain the current resource base and enhance its potential. Artificial structures in the marine environment are a response to this need. Marine parks, fisheries management regimes, coastal area management and zonation schemes are attempts to protect and manage the marine environment for long-term and sustainable use. But these may not be enough. Now, we need to rehabilitate. We must understand the differences between artificial structures as a means to achieve these ends and the broader protection and management schemes. Artificial structures in the sea can work well within these broader schemes, but they can not replace marine habitats. There is no replacement for the normal functioning and sound management of a healthy marine ecosystem and its associated benefits. Humans can not replace these through manipulation and with artificial means.

For the benefit of the marine environment and ourselves, we can be creative in the management of resources and in the design of artificial structures. Planning for multipurpose artificial reefs is a step in this direction. An example might be a concrete reef designed to function as a rearing reef and as a submerged breakwater.⁵⁰ Such a reef could enhance fisheries productivity by (1) supplying new habitat and space and (2) improving hydraulic conditions by speeding or deviating currents and increasing water exchange in the site.⁶⁰ One such reef for abalone was designed in Japan to obtain circular currents that would avoid dispersion of shell larvae out of the artificial reef ground. The recruitment of abalone larvae on the reef was considerably improved over other reef designs (Fig. 17).⁶⁰

Planning Considerations

The design and propagation of artificial reefs in the marine environment is still more of an art than a science. Yet, much experience has been gained in the last 20 years in those countries interested in fisheries and habitat management in coastal areas. These experiences have pointed to some lessons in the design and

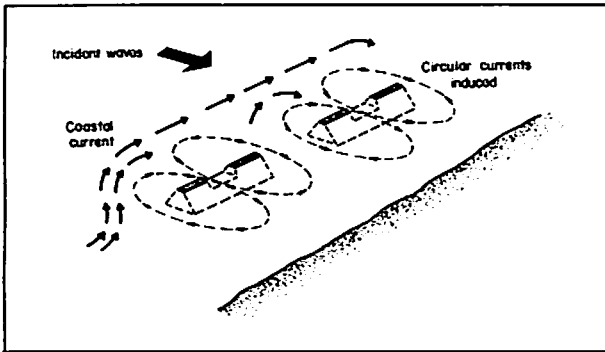

Fig. 17. Creation of circular currents with submerged breakwaters to enhance recruitment of abalone larvae.⁶⁰

planning of artificial reefs to make them more effective in future habitat enhancement projects. Some important considerations are:^{60,9}

1. The area of reef placement should be surveyed for biological productivity, important ecological relations, target species and common physical factors such as depth, bottom topography, currents, tides, visibility and bottom substrate.
2. The overall planning decisions should cover location of the reefs, arrangement of reef groups and the architecture of reef units.
3. The basics of reef architecture should be included in a reef design so that materials and location are optimally used. In this context, the design criteria are:
 - a. reef volume and volume of interstitial spaces and size of holes and openings;
 - b. reef height and profile in relation to prevailing currents and for attracting fish and providing turbulence, lee waves and shadows; and
 - c. possible maximum contact surface between the reef and the water for better colonization by sessile organisms and enough space for fish to hide and for fishing gear to enter whenever appropriate.
4. The proposed reef and its site should be analyzed for its capability to attract fish or increase fish biomass so that management goals could be achieved. Criteria for evaluation in relation to the tendency for fish attraction are:⁹
 - a. level of fishing effort (if high, a reef may exacerbate overfishing);
 - b. biomass relative to catch (if low, a reef may exacerbate overfishing);
 - c. natural fish density (if low, it indicates a need for fish aggregation); and
 - d. stock immigration (if high, a reef may exacerbate overfishing).

tection, marine parks and restoration techniques, etc.). If used sensibly within more comprehensive management approaches, artificial reefs can contribute to the success of these approaches; but if they are used as a cure-all for overfishing and habitat destruction, without regard for the broader coastal resources management context, they could end in failure.

Glossary

Artificial reef - a structure constructed by people and installed in a certain part of the sea; it is intended for fisheries productivity and/or habitat enhancement; it mimics natural reefs.

Cost/benefit analysis - analysis which determines whether total benefits are higher or lower than costs for a particular project (i.e., if benefits are higher than costs, a project is worth doing).

Efficiency of an artificial reef - the degree to which it performs the functions of a natural reef and is durable within the marine environment.

Fish Aggregating Device (FAD) - artificially built structure installed in the sea water column or surface and/or natural materials such as leaves intended to concentrate mobile fish populations.

Fish yield - portion of a fish population that is extracted through fishing effort; measured in weight/time.

Net productivity - the rate at which biomass is produced at some specified trophic level.

Productivity - the rate at which biological products attributed to an ecosystem are produced over time.

Reef - a sea bottom feature which has some topographic relief such as a ridge. Rocks or sand, often of living or dead coral, at or near the surface of the water.

Reef assemblage - the association of various organisms within a particular reef which depends on the reef substrate and organisms for habitat and subsistence.

Reef complex - reef groups arranged near each other and covering a large area.

Standing crop - the amount of biomass present at a specific time.

Unit reef - the smallest division of an artificial reef complex which constitutes a single reef (e.g., a tire module, bamboo structure or concrete module).

References

1. Alcala, A.C. 1979. Fish standing stock and yield of an artificial reef off Bantayan, Dumaguete City, Philippines. *Silliman J.* 26(4): 253-262.
2. Alcala, A.C. 1987. Artificial reefs. Proceedings of the International Symposium on Artificial Reefs, August 1987. Miami, Florida.
3. Alcala, A.C. and M. de los Reyes. 1987. Executive summary: artificial reefs. Bureau of Fisheries and Aquatic Resources, Department of Agriculture, Philippines.
4. Alcala, A.C., L.C. Alcala, E.D. Gomez, M.E. Cowen and H.T. Yap. 1981. Growth of certain corals, molluscs and fish in artificial reefs in the Philippines, p. 215-220. Proceedings of the Fourth International Coral Reef Symposium, 18-22 May 1981. Vol. 2. Marine Sciences Center, University of the Philippines, Quezon City, Philippines.
5. Anon. 1979. Guide to artificial reefs. New South Wales State Fisheries Leaflet No. 6.
6. Anon. 1980. Placing rocks for the culture of sea cucumbers. *Suisan Keizai Shimbum* December (8136): 2.
7. Barreto, E.F.C. 1986. Fish recruitment with notes on productivity in a bamboo artificial reef. University of the Philippines, Quezon City, Philippines. 87 p. M.S. thesis.
8. Bernard, W. 1979. How to build an artificial reef of tires. *Silliman J.* 26(4): 263-268.
9. Bohnsack, J.A. 1989. Are high densities of fishes at artificial reefs the result of habitat limitation on behavior preference? *Bull. Mar. Sci.* 44(2): 631-645.
10. Bohnsack, J.A. and D.L. Sutherland. 1985. Artificial reef research: a review with recommendations for future priorities. *Bull. Mar. Sci.* 37(1): 11-39.
11. Bojos, R.M., Jr. and F.J. Vande Vusse. 1988. Artificial reefs in Philippine artisanal fishery rehabilitation. Paper presented at ASEAN/UNDP/FAO Regional Small-scale Coastal Fisheries Development and Management, 13-16 September 1988. Penang, Malaysia.
12. Bombace, G. 1980. Note on experiments in artificial reefs in Italy. FAO Symposium on the Management of Living Resources in the Mediterranean Coastal Area. GFCM/XV/80/21. 12 p. Istituto di Tecnologia della Pesca, Molo Mandracchio, Ancona, Italy. (In Italian).
13. Brock, R.E. and R.M. Buckley. 1984. A proposed fisheries enhancement program based on artificial reefs for nearshore Hawaiian waters. *Sea Grant Univ. Hawaii* 6(1): 8 p.
14. Buchanan, C.C. 1973. Effects of an artificial habitat on the marine sport fishery and economy of Murrells Inlet, South Carolina. *Mar. Fish. Rev.* 35(9): 15-22.
15. Buckley, R.M. 1982. Marine habitat enhancement and urban recreational fishing in Washington. *Mar. Fish. Rev.* 44(6/7): 28-37.
16. Buckley, R.M. 1985. Habitat enhancement and urban recreational fishing, p. 365-382. *In* F.M. D'Itri (ed.) Artificial reefs: marine and freshwater applications. Lewis Publishers, Inc. Michigan, USA.
17. Ch'ng, K.M. and C. Thomas. 1990. Artificial reef program in Malaysia. *In* L.M. Chou, T.-E. Chua, H.W. Khoo, P.E. Lim, J.N. Paw, G.T. Silvestre, M.J. Valencia, A.T. White and P.K. Wong (eds.) Towards an integrated management of tropical coastal resources. ICLARM Conference Proceedings 22. National University of Singapore, Singapore; Science Council of Singapore, Singapore; and International Center for Living Aquatic Resources Management, Philippines.
18. Chou, L.M. 1989. The commercial and recreational values of artificial reefs. *J. Sing. Natl. Acad. Sci.* 17: 50-52.
19. Chou, L.M. and A.T. White. 1987. Artificial habitats, p. 60-63. *In* T.-E. Chua, L.M. Chou and M.S.M. Sadorra (eds.) The coastal environmental profile of Brunei Darussalam: resource assessment and management issues. ICLARM Technical Reports 18, 193 p. Fisheries Department, Ministry of

Development, Brunei Darussalam; and International Center for Living Aquatic Resources Management, Manila, Philippines.

20. Cognetti, G. 1987. Editorial: Artificial reefs--myth or reality? *Mar. Pollut. Bull.* 18(7): 367-368.

21. De Silva, M.W.R.N. 1988. Artificial reefs: a practical means to enhance living marine resources, p. 173-180. *In* T.-E. Chua and D. Pauly (eds.) *Coastal area management in Southeast Asia: policies, management strategies and case studies*. ICLARM Conference Proceedings 19, 254 p. Ministry of Science, Technology and the Environment, Kuala Lumpur; Johore State Economic Planning Unit, Johore Bahru, Malaysia; and International Center for Living Aquatic Resources Management, Manila, Philippines.

22. Edmund, N.W. 1967. Old tires: the ideal material for building fish havens. Edmund Scientific Co., New Jersey.

23. Fast, D.E. and F.A. Pagan. 1974. Comparative observations of an artificial tire reef and natural patch reefs off southwestern Puerto Rico, p. 49-50. *In* L. Colunga and R. Stone (eds.) *Proceedings of the Artificial Reef Conference*. TAMU-SG-74-103. Texas A & M University.

24. Floyd, J. and D. Pauly. 1984. Smaller size tuna in the Philippines: can fish aggregating devices be blamed? *Infish Mark. Dig.* 5(84): 25-27.

25. Gomez, E.D., A.C. Alcalá and L.C. Alcalá. 1982. Growth of some corals in an artificial reef off Dumaguete, Central Visayas, Philippines. *Kalikasan: Philipp. J. Biol.* 11(1): 148-157.

26. Grove, R.S. and J. Sonu. 1983. Review of Japanese fishing reef technology. Southern California Edison Co., CA.

27. Hecker, S. and E.A. Kennedy. 1988. Preliminary studies for the development of artificial reef siting plans in the northeastern gulf of Mexico. Paper presented at the University of North Carolina, Wilmington, USA.

28. Hilbertz, W.H. 1981. The electrodeposition of minerals in sea water for the construction and maintenance of artificial reefs, p. 123-148. *In* D.Y. Aska (ed.) *Artificial reefs: conference proceedings*. Fla. Sea Grant Coll. Rep. 41. Gainesville, Florida.

29. Holbrook, J.E. 1860. *Ichthyology of South Carolina*. 2nd ed. Charleston, South Carolina.

30. Ino, T. 1974. Historical review of artificial reef activities in Japan, p. 21-23. *In* L. Colunga and R. Stone (eds.) *Proceedings of the Artificial Reef Conference*. TAMU-SG-74-103. Texas A & M University.

31. Iversen, E.S. and S.P. Bannerot. 1984. Artificial reefs under marina docks in Southern Florida. *N. Am. J. Fish. Manage.* 4: 294-299.

32. Iwashita, M. 1977. Present status and future prospects of the fisheries industry of Japan, p. 6-9. *In* *Proceedings of the Fourth Soviet-Japan Joint Symposium on Aquaculture*, September-October 1975. Tallinn, Estonia, USSR.

33. Miclat, R.I. 1987. Progress report on the continuing Artificial Reef Development Project on BFAR. Report presented at the 1987 Philippine Council for Agriculture and Resources Research and Development Regional Integrated R & D Review and Planning Workshop, 29 June-3 July. Quezon City, Philippines.

34. Miclat, R. and E. Miclat. 1989. Artificial reefs: a fisheries management tool for Lingayen Gulf, p. 109-117. *In* G. Silvestre, E. Miclat and T.-E. Chua (eds.) *Towards sustainable development of the coastal resources of Lingayen Gulf, Philippines*. ICLARM Conference Proceedings 17, 200 p. Philippine Council for Aquatic and Marine Research and Development, Los Baños, Laguna, and International Center for Living Aquatic Resources Management, Makati, Metro Manila, Philippines.

35. Moffitt, R.B., F.A. Parrish and J.J. Polovina. 1989. Community structure, biomass and productivity of deepwater artificial reefs in Hawaii. *Bull. Mar. Sci.* 44(2): 616-630.

36. Mottet, M.G. 1981. Enhancement of the marine environment for fisheries and aquaculture in Japan. *Wash. Dept. Fish. Tech. Rep.* 69. 96 p.

37. Mottet, M.G. 1986. Enhancement of the marine environment for fisheries and aquaculture in Japan, p. 13-112. *In* F.M. D'Itri (ed.) *Artificial reefs: marine and freshwater applications*. Lewis Publishers, Inc., Michigan, USA.

38. Munro, J.L. and O. McB. Williams. 1985. Assessment and management of coral reef fisheries: biological, environmental and socioeconomic aspects, p. 544-578. *In* Proceedings of the Fifth International Coral Reef Congress, 25 May-1 June 1985. Tahiti, French Polynesia. Vol. 4. Antenne Museum-EPHE, Moorea, French Polynesia.
39. Murdy, E.O. 1979. Fishery ecology of the Bolinao artificial reef. *Kalikasan: Philipp. J. Biol.* 8: 121-154.
40. Murdy, E.O. 1980. The commercial harvesting of tuna-attracting payaos: a possible boon for small-scale fishermen. *ICLARM Newsl.* 3(1): 10-13.
41. Myatt, D.O. 1982. Application of midwater fish attractors for recreational fishery improvement in the South Atlantic bight, p. 10. *In* J.D. Murray (comp.) Mid-Atlantic artificial reef conference: a collection of abstracts. New Jersey Sea Grant Rep. 82-78.
42. Ogawa, Y. 1977. Artificial fish reefs and bank building for fisheries enhancement. *Suisan Doboku*: 7-11. (In Japanese).
43. Ogawa, Y., S. Takeuchi and A. Hattori. 1977. An estimate for the optimum size of artificial reef. *Bull. Jap. Soc. Fish. Oceanogr.* 30: 39-45.
44. Ogden, J.C. and J.P. Ebersole. 1981. Scale and community structure of coral reefs in the Virgin Islands. *Carrib. J. Sci.* 3: 31-47.
45. Pauly, D. and T.-E. Chua. 1988. The overfishing of marine resources: socioeconomic background in Southeast Asia. *Ambio* 17(3): 200-206.
46. Paxton, K.O. and F. Stevenson. 1979. Influence of artificial structures on angler harvest from Killdeer Reservoir, p. 70-76. *In* D.L. Johnson and R.A. Stein (eds.) Response of fish to habitat structure in standing water. *Am. Fish. Soc. Spec. Publ.* 6.
47. Polovina, J.J. 1989a. Artificial reefs: nothing more than benthic fish aggregates. *CalCOFI Rep.* 30: 37-39.
48. Polovina, J.J. 1989b. Part III: Should anyone build reefs? *Bull. Mar. Sci.* 44(2): 1056-1057.
49. Polovina, J.J. and I. Sakai. 1989. Impacts of artificial reefs on fishery production in Shimamaki. *Jap. Bull. Mar. Sci.* 44(2): 997-1003.
50. Pramokchutima, S. and S. Vadhanakul. 1987. The use of artificial reefs as a tool for fisheries management in Thailand. Department of Fishery, Ministry of Agriculture and Cooperatives, Bangkok, Thailand.
51. Randall, J.E. 1963. An analysis of the fish populations of artificial and natural reefs in the Virgin Islands. *Carrib. J. Sci.* 3: 31-47.
52. Samples, K.C. and J.T. Sproul. 1985. Fish aggregating devices and open-access commercial fisheries: a theoretical inquiry. *Bull. Mar. Sci.* 37(1): 305-317.
53. Sato, O. 1985. Scientific rationales for fishing reef design. *Bull. Mar. Sci.* 37(1): 329-335.
54. Schroeder, R.E. 1987. Effects of patch reef size and isolation on coral reef fish recruitment. *Bull. Mar. Sci.* 4(12): 441-451.
55. Sheehy, D.J. 1981. Artificial reef programmes in Japan and Taiwan, p. 185-198. *In* D.Y. Aska (ed.) Artificial reefs: conference proceedings. Fla. Sea Grant Coll. Rep. 41. Gainesville, Florida.
56. Sheehy, D.J. 1986. New approaches in artificial reef design and applications, p. 253-263. *In* F.M. D'Itri (ed.) Artificial reefs: marine and freshwater applications. Lewis Publishers, Inc., Michigan, USA.
57. Shimizu, T. 1981. On the distribution of fish schools at the artificial fish reef ground off Nagai, Kanagawa Prefecture. *Bull. Kanagawa Prefect. Fish. Exp. Stn.* 3: 1-7.
58. Shinn, E.A. 1974. Oil structures as artificial reefs, p. 91-96. *In* L. Colunga and R. Stone (eds.) Proceedings of the Artificial Reef Conference. TAMU-SG-74-103. Texas A & M University.
59. Stone, R.B. 1985. History of artificial reef use in the United States, p. 3-11. *In* F.M. D'Itri (ed.) Artificial reefs: marine and freshwater applications. Lewis Publishers, Inc., Michigan, USA.
60. Thiery, J.M. 1988. Artificial reefs in Japan: a general outline. *Aquacult. Eng.* 7: 321-348.
61. Turner, C.H., E.E. Ebert and R.R. Given. 1969. Man-made reef ecology. *Fish. Bull. Dep. Fish. Game Calif.* 146. 221 p.

62. Vande Vusse, F. 1989. Concrete artificial reef guide. Central Visayas Regional Project, Cebu, Philippines. (Unpublished).
63. White, A.T. 1987. Coral reefs: valuable resources of Southeast Asia. ICLARM Education Series 1, 36 p. International Center for Living Aquatic Resources Management, Philippines.
64. White, A.T. and G. Savina. 1987. Reef fish yield and non-reef catch off Apo Island, Negros, Philippines. *Asian Mar. Biol.* 4(1987): 67-76.
65. Whittaker, R.H. 1975. *Communities and ecosystems*. 2nd ed. MacMillan, New York.
66. Woodhead, P.M.J., H.J. Parker and I.W. Duedall. 1982. The coalwaste artificial reef program (C-WARP): a new resource potential for fishing reef construction. *Mar. Fish. Rev.* 44(6-7): 16-23.
67. Yoshimuda, N. and Y. Fujii. 1982. Artificial reef scale and installation conditions, p. 148-159. *In* S.F. Vik (ed.) *Japanese artificial reef technology*. Aquabio. Fla. Tech. Rep. 604.

**ICLARM EDUCATION SERIES
ON COASTAL AREA MANAGEMENT**

Coral reefs: valuable resources of Southeast Asia. A.T. White. 1987. No. 1, 36 p. Out of print - available at cost in photocopied form only.

Marine parks and reserves: management for coastal environments in Southeast Asia. A.T. White. 1988. No. 2, 36 p. \$1.50 surface; \$5 airmail.

May pangako mula sa dagat (comics on blast fishing, in Pilipino). L.M. Cabrera. 1988. No. 3, 26 p. Free upon request.

There is still hope (comics on marine parks). 1989. No. 4, 14 p. Out of print - available at cost in photocopied form only.

Seagrasses: a resource unknown in the ASEAN region. M.D. Fortes. 1989. No. 5, 46 p. \$1.50 surface; \$5 airmail.

Artificial reefs for marine habitat enhancement in Southeast Asia. A.T. White, L.M. Chou, M.W.R.N. De Silva and F.Y. Guarin. 1990. No. 11, 45 p. \$1.50 surface; \$5 airmail.

Mail orders and inquiries to:

- International Specialized Book Services, P.O. Box 1632, Beaverton, Oregon 97075, USA (for North America). Airmail price must be used.
- S. Toeche-Mittler GmbH, Versandbuchhandlung, Hindenburgstrasse 33, D-6100 Darmstadt, Federal Republic of Germany (for Europe). Airmail price must be used.
- The Editor, ICLARM, MC P.O. Box 1501, Makati, 1299 Metro Manila, Philippines (for inquiries elsewhere). Send US\$ by international money order, bankdraft or UNESCO coupons payable to ICLARM. We can accept US\$ checks only if from a US-based bank due to high clearance fees of other banks.

Airmail is strongly recommended due to delays of up to 6 months and occasional losses experienced with surface mail.

For more information on the Coastal Area Management Program (CAMP), contact: The Director, CAMP, ICLARM, MC P.O. Box 1501, Makati, 1299 Metro Manila, Philippines. Cable: ICLARM MANILA. Telex: (ETPI) 64794 ICLARM PN. (US Telex line) 49000 10376 ICL UI. FAX: (63-2)816-3183; (63-2)819-3329 ATTN:ICS 406. Tel. nos. 818-9283; 818-0466; 817-5255.